

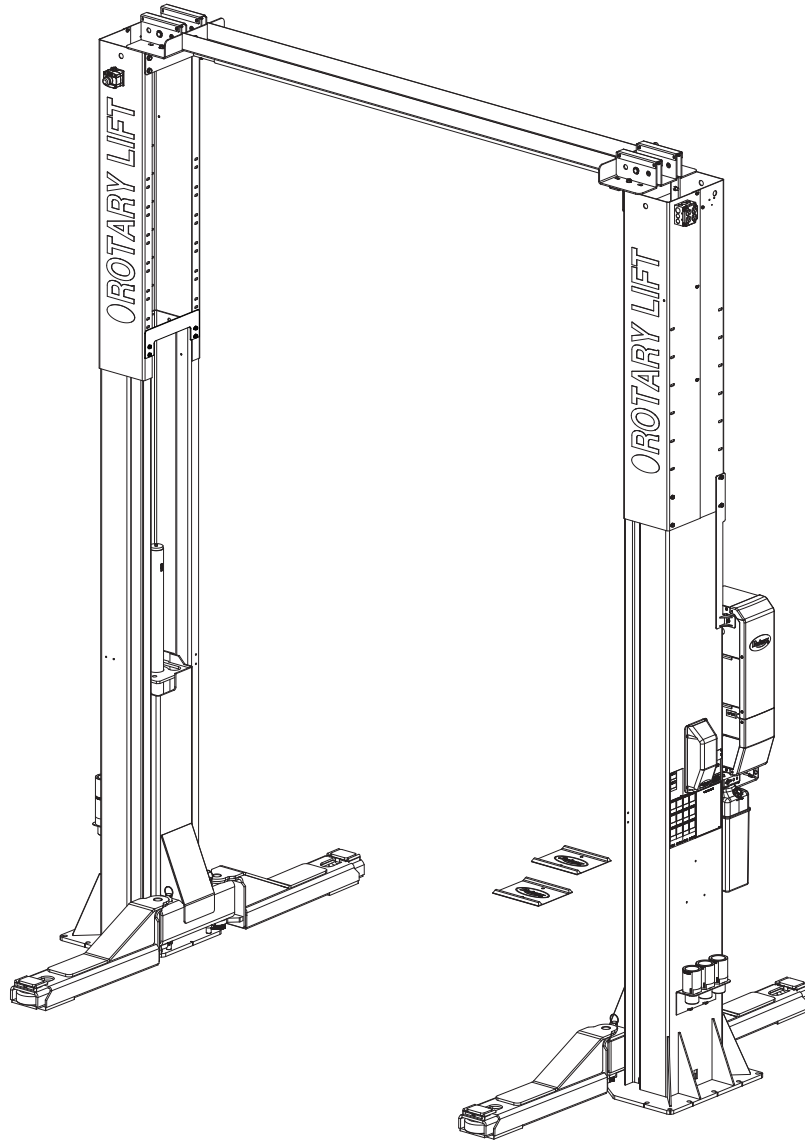

# SP016, SP020

SP016 Capacity 16,000 lbs. (7,258 kg.) / 4,000 lbs. (1,814 kg.) per Arm  
SP020 Capacity 20,000 lbs. (9,072 kg.) / 5,000 lbs. (2,268 kg.) per Arm



**OPERATING CONDITIONS**  
Lift is not intended for outdoor use  
and has an operating ambient temperature  
range of  
41°-104°F (5°-40°C)

**LP20650**

C010473

**I  
N  
S  
T  
A  
L  
L  
A  
T  
I  
O  
N  
-  
I  
N  
S  
T  
R  
U  
C  
T  
I  
O  
N  
S**

**1. Lift Location:** Use architects plan when available to locate lift. Fig. 1 shows dimensions of a typical bay layout.

**⚠️ WARNING** DO NOT install this lift in a pit or depression due to fire or explosion risks. A forklift is recommended to upright each column during installation.

**Note:** Installation tip - Upright each column after installing column extensions, column ties, and overhead brackets.

**2. Lift Setting:** Position columns in bay using dimensions shown in Fig.1. Place column with power unit mounting bracket on vehicle passenger side of lift. Both column base plate backs must be square on center line of lift. Notches are cut into each base plate to indicate center line of lift.

Use appropriate equipment to raise carriage to first latch position. Be sure locking latch is securely engaged.

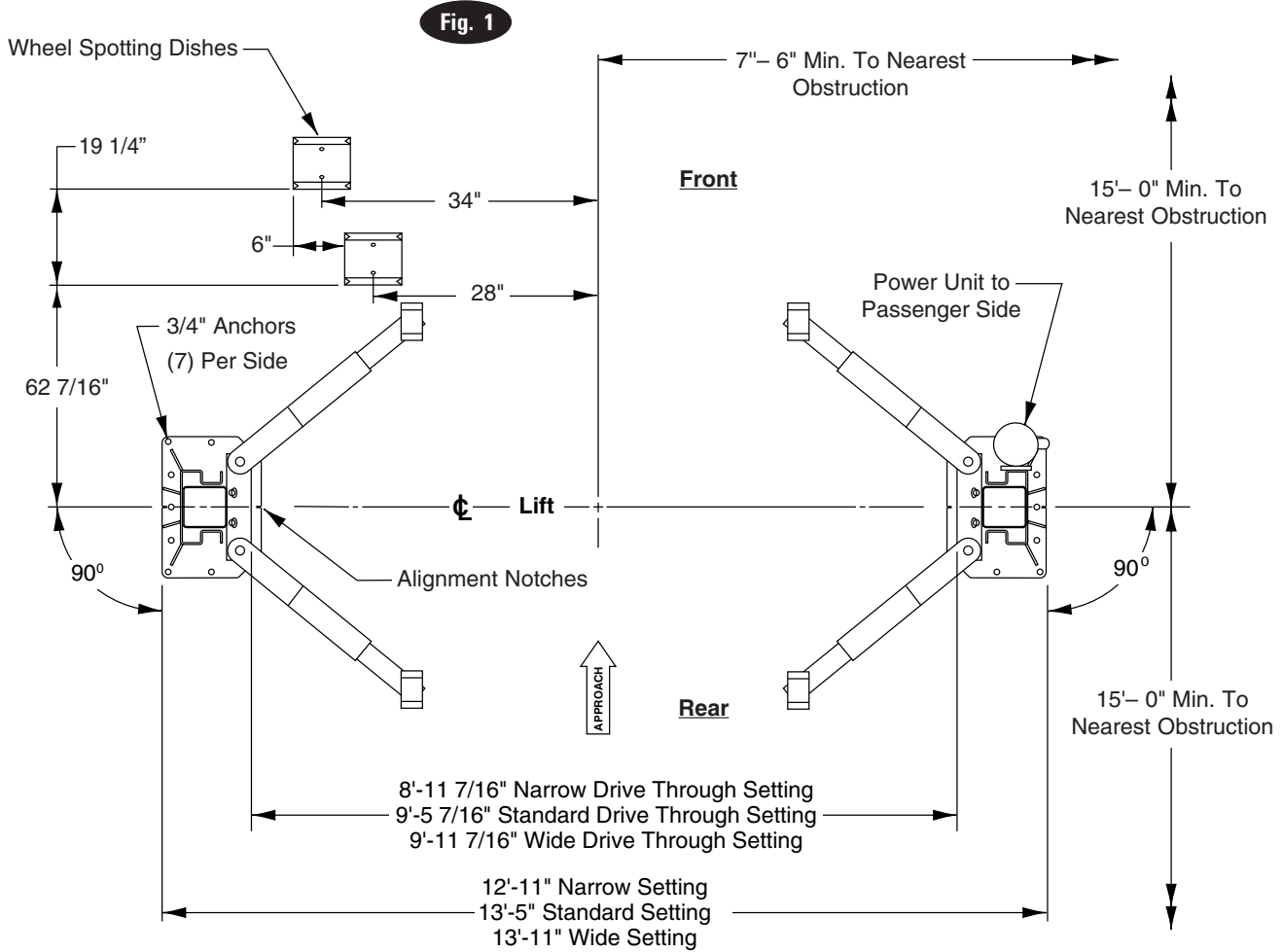

**3. Lift Height:** See Fig. 2 for overall lift height of each specific lift model. Add 1" min. to overall height to lowest obstruction.

**4. Install Column Extensions** to columns using (4) 3/8"-16NC x 1/2" Lg. Flanged HHCS and (3) 1/4"-20NC x 5/8" Lg. Flanged HHCS with (3) 1/4"-20NC Lock Nut, Fig. 3.

Install column ties using (4) 3/8"-16NC x 1" Flanged HHCS, Fig. 4 and (4) 3/8"-16NC Flanged Lock Nuts. Adjust column extensions square and tighten hardware.

Fig. 2

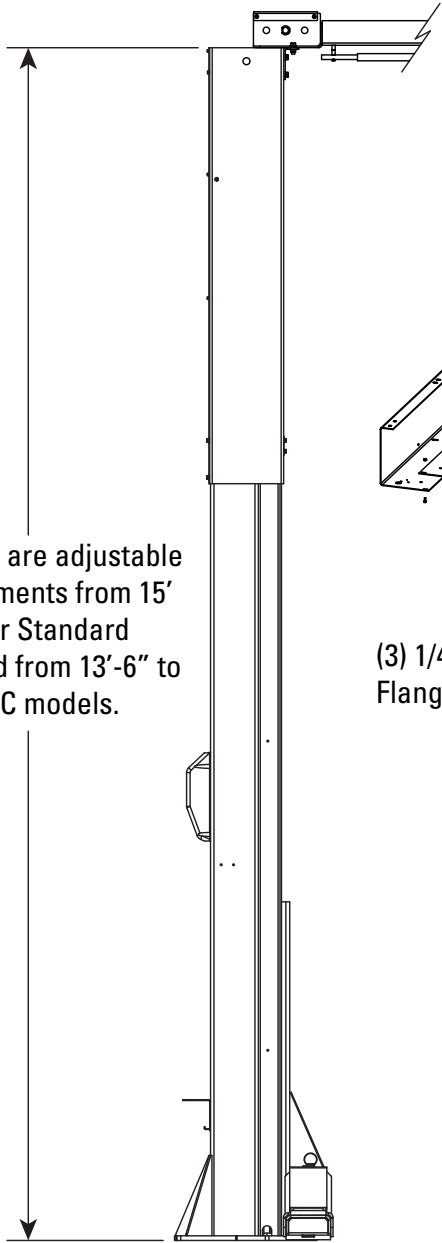

Extensions are adjustable in 6" increments from 15' to 16'-6" for Standard models and from 13'-6" to 14'-6" for LC models.

Fig. 3

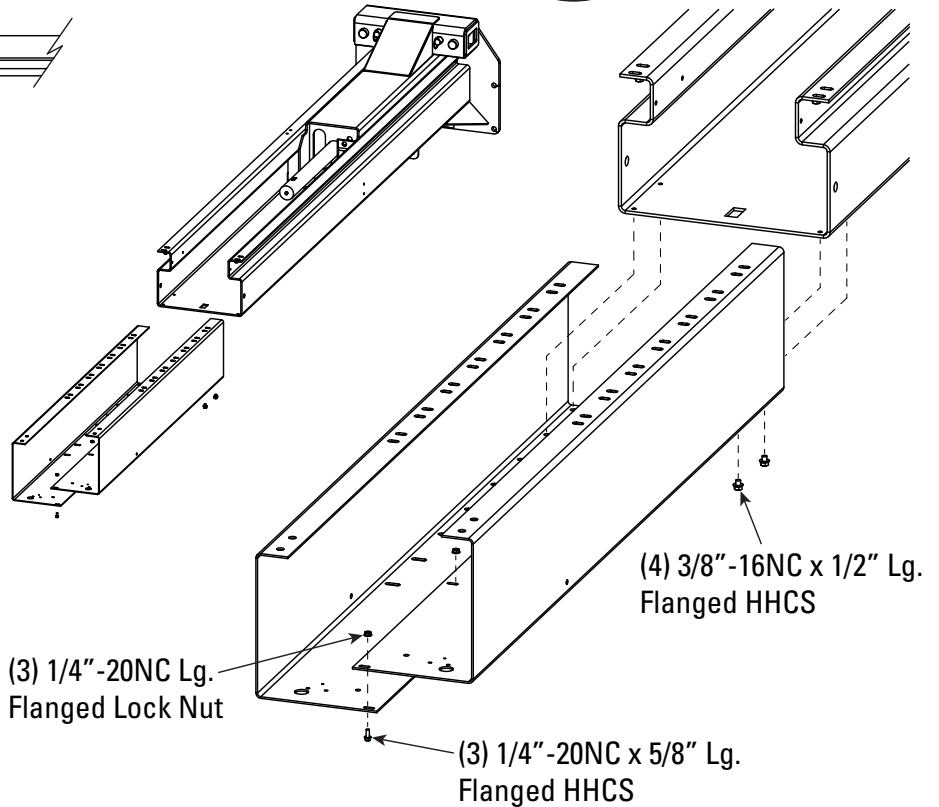
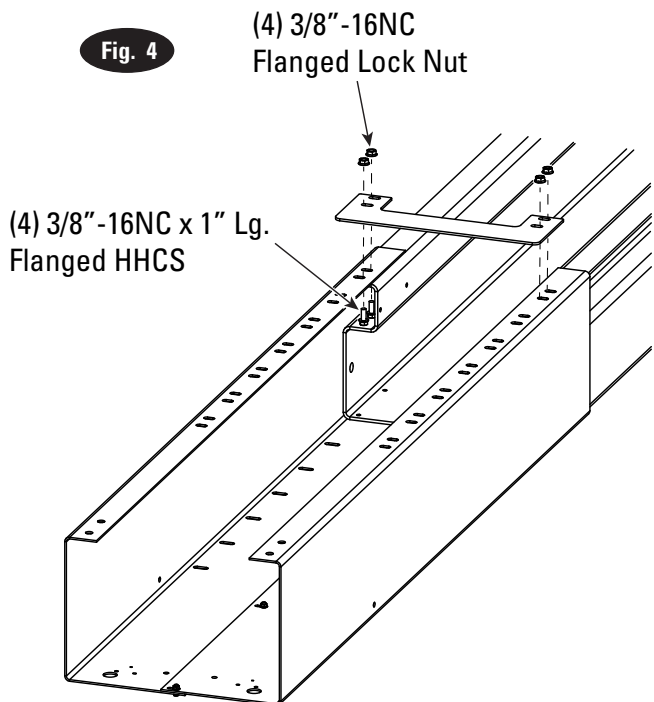
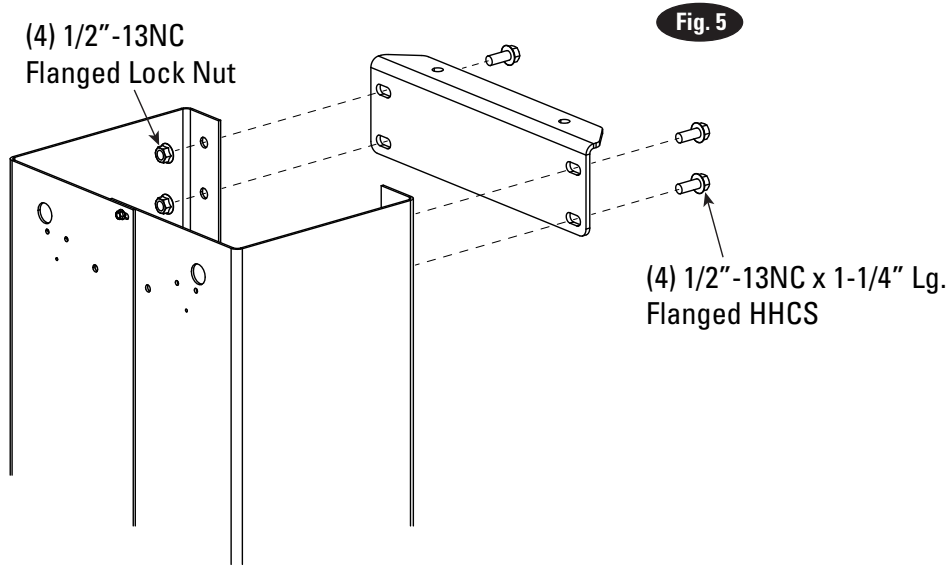

Fig. 4



**5. Attach Overhead Bracket** to column extensions using (4) 1/2"-13NC x 1-1/4" Lg. Flanged HHCS and (4) 1/2"-13NC Flanged Locknut, Fig. 5.



**6. Attach overhead assembly** to overhead bracket with (2) 1/2"-13NC x 1-1/4" Lg. Flanged HHCS and (2) 1/2"-13NC Flanged Locknut. Install (2) cover brackets using (4) 1/4"-20NC x 5/8" Lg. Flanged HHCS (2 per bracket) and (4) 1/4"-20NC Flanged Locknut (2 per bracket), Fig. 5a.

**Notice**, the cover brackets cannot be installed until after cables have been routed and installed, Fig. 15.

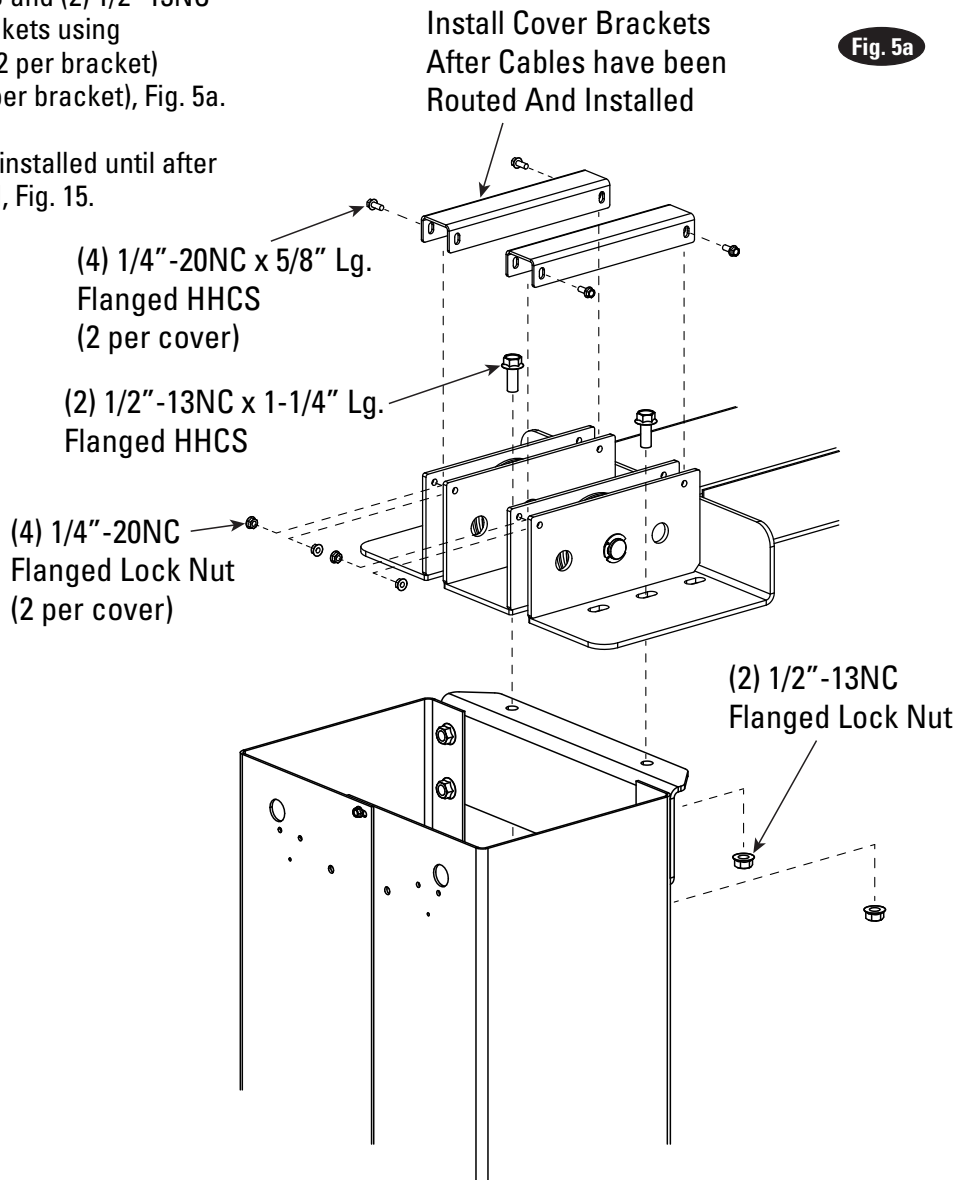

**Concrete and Anchoring:**

Drill (14) 3/4" dia. holes (7 per side) in concrete floor using holes in column base plate as a guide. See diagrams for hole depth, hole spacing, and edge distance requirements.

**CAUTION** DO NOT install on asphalt or other similar unstable surfaces. Columns are supported only by anchors in floor.

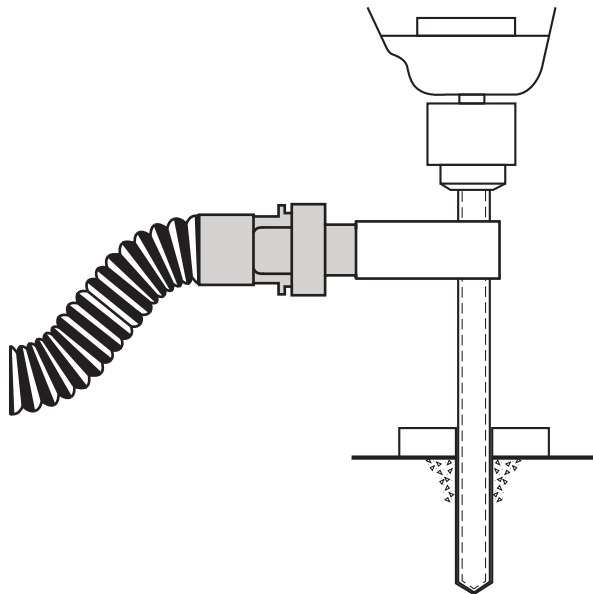

Drill holes using 3/4" carbide tipped masonry drill bit per ANSI B212.15-1994 (R2000). Construction dust collected per OSHA 29 CFR 1926.1153.

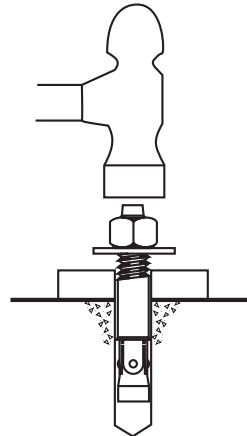

Run nut down just below impact section of bolt. Drive anchor into hole until nut and washer contact base.

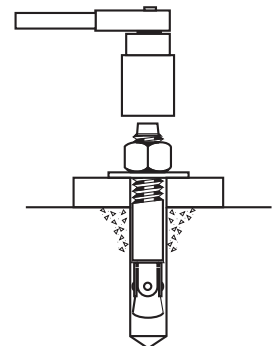

Tighten nut with Torque wrench to 110 ft.-lbs.

CONCRETE AND ANCHORING REQUIREMENTS				
STANDARD	ANSI/ALI ALCTV	IBC		SEISMIC
Minimum Floor Thickness	4-1/4 INCHES	5 INCHES	6 INCHES	Varies by location consult with your structural engineer and manufacturer's representative.
Anchor	Hilti Kwik Bolt III 3/4" x 5-1/2" Anchors supplied with the lift.*	Hilti HIT-HY 150 MAX-SD Adhesive; Hilti HIT-HY 150 MAX Adhesive; HILTI HIT-RE 500-SD Adhesive	Hilti Kwik Bolt III 3/4" x 7"	
Minimum Concrete Strength	3000 PSI	3000 PSI	3000 PSI	
Minimum Anchor Embedment	3-1/4 INCHES	3-1/2 INCHES	3-3/4 INCHES	
Minimum Distance to Concrete Edge, Crack, Expansion Joint, Abandoned Anchor Hole	4-1/2 INCHES	5-1/4 INCHES	3-1/4 INCHES	
<p><b>*The supplied concrete fasteners meet the criteria of the American National Standard "Automotive Lifts - Safety Requirements for Construction, Testing, and Validation" ANSI/ALI ALCTV-2017, and the lift owner is responsible for all charges related to any additional anchoring requirements as specified by local codes. Contact customer service for further information at: 800.445.5438</b></p>				

**7. IMPORTANT:** Using the horse shoe shims provided, shim each column base until each column is plumb. If one column has to be elevated to match the plane of the other column, full size base shim plates should be used (Reference Shim Kit N774-1 Shim). Recheck columns for plumb. Tighten anchor bolts to an installation torque of 110 ft-lbs. Shim thickness **MUST NOT** exceed 1/2" when using the 5-1/2" long anchors provided with the lift, Fig. 6.

If anchors do not tighten to 110 ft-lbs. installation torque, replace concrete under each column base with a 6' x 6' x 6" thick 3000 PSI minimum concrete pad keyed under and flush with the top of existing floor. Let concrete cure before installing lifts and anchors.

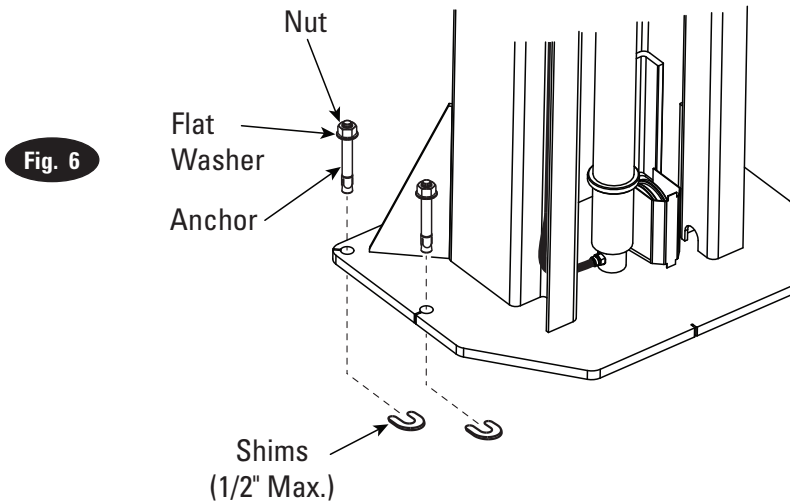

**NOTE:** If more than 2 horse shoe shims are used at any of the column anchor bolts, pack non-shrink grout under the unsupported area of the column base. Insure shims are held tightly between the baseplate and floor after torquing anchors.

**8. Mount Switch** assembly towards power unit column as shown, Fig. 7, using (2) 1/4"-20NC x 3/4" lg. HHCS, nuts and Washers.

Insert 1/4"-20NC x 2-3/4" HHCS through pivot hole in end of switch bar. Insert opposite end of bar through slot in switch mounting bracket, Fig. 7a. Then secure HHCS and Switch Bar to overhead as shown, Fig. 7, using (2) 3/4" spacers and 1/4"-20NC Locknut. Tighten Hex bolt leaving 1/16" gap between the spacer and the overhead assembly.

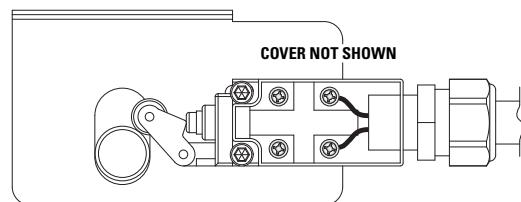
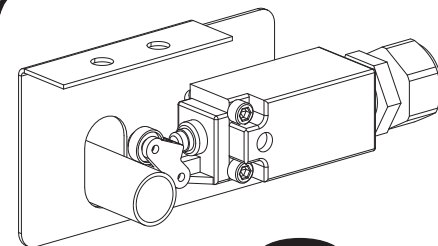
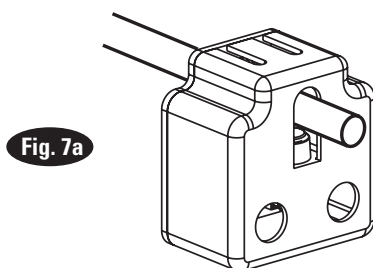
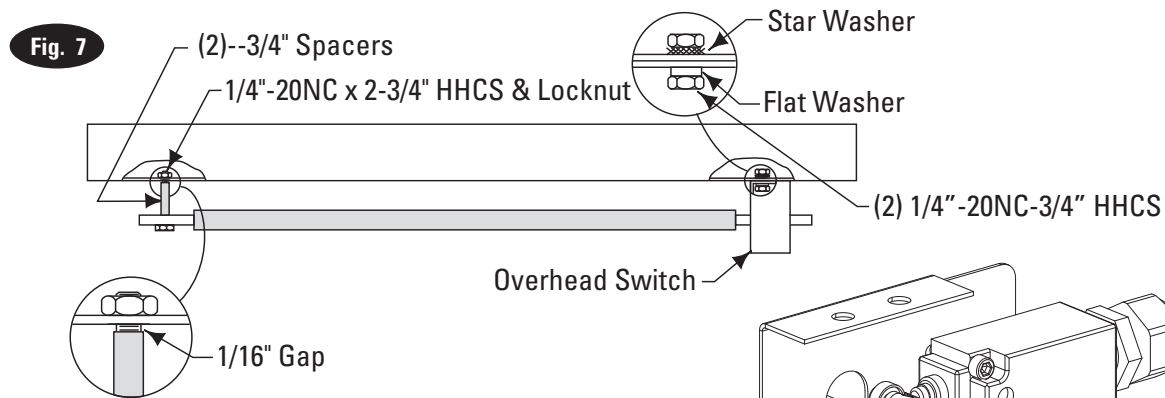

9. Mount latch release air valve and bracket to column using (2) 5/16"-18NC x 3/8" lg. PHMS, Fig. 8.

Fig. 8

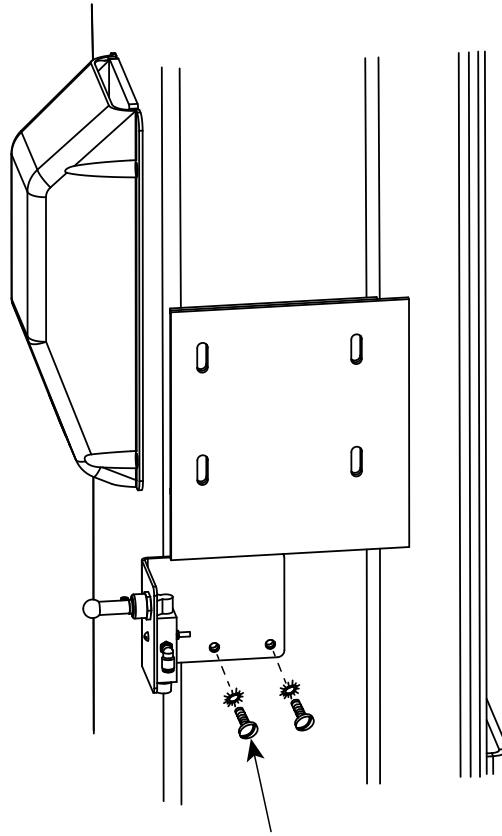

(2) 5/16" x 3/8" Lg. Pan Head Screw  
With (2) 5/16" Ext. Tooth Lockwashers

## Single Phase Power Unit (For DC Version see pages 14-23)

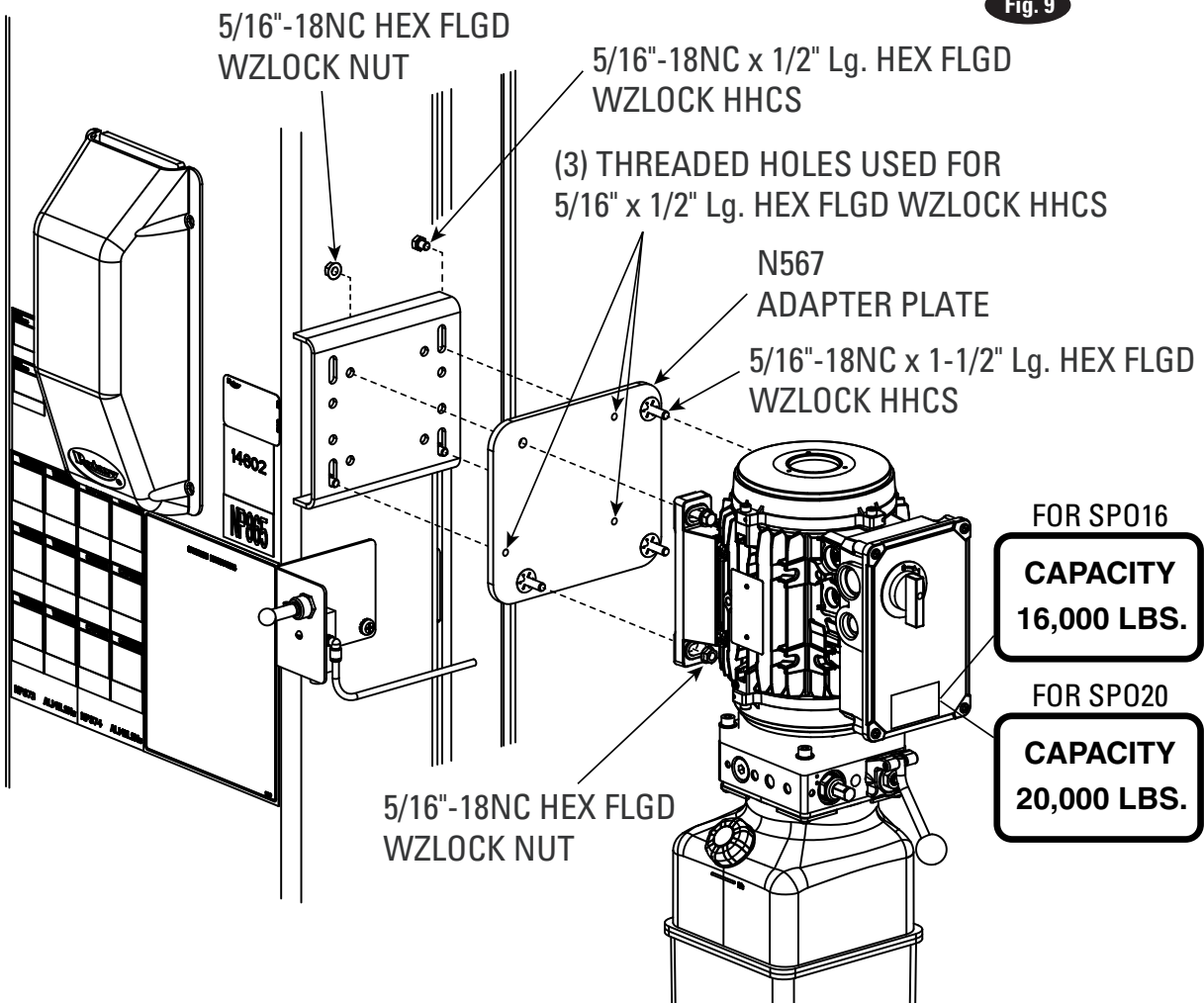

### 10. Single Phase Power Unit:

- A)** Attach (3) 5/16"-18NC x 1 1/2" lg. flange head cap screws to the adapter plate as shown with push nuts.
- B)** Attach the adapter plate to the column power unit bracket with (3) 5/16"-18NC x 1/2" lg. flange head cap screws as shown.
- C)** Attach the power unit to the adapter plate using the existing 1/2" lg. hardware and 5/16"-18NC flange head nuts.
- D)** Add the last 5/16"-18NC x 1 1/2" lg. flange head cap screw and nut (upper left as shown) to complete the power unit installation, Fig. 9.
- E)** Attach straight thread adapter, swivel elbow, flow control regulator, and o-ring face seal tee as shown, Fig. 10.

**CAUTION** Over tightening locknut may tear O-ring or distort threads in pump manifold outlet.

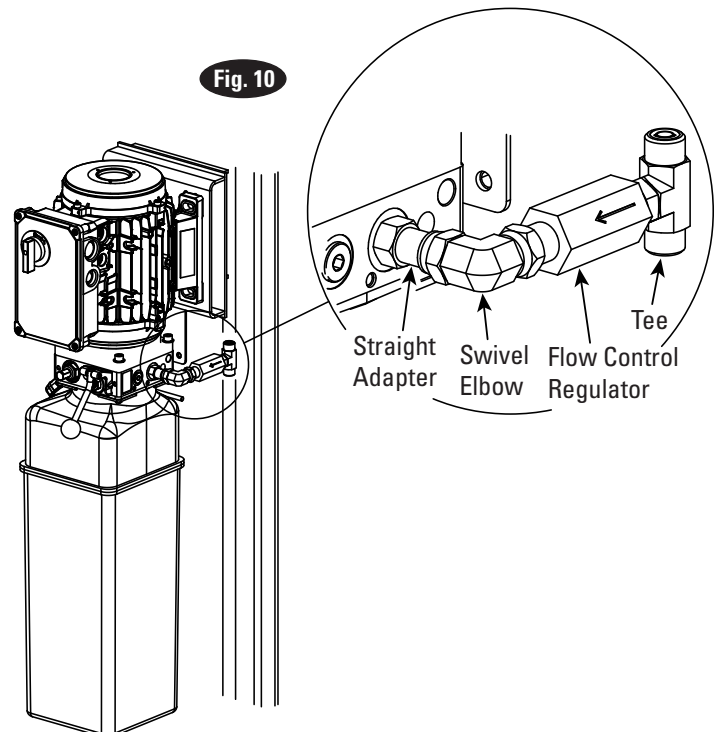



**11. Hoses:** Clean adapters and hose. Inspect all threads for damage and hose ends to be sure they are crimped.

**Adapter & Hose Installation**

- A)** Install item (2) with hose clamps, on power unit column side connecting it to the cylinder (1) first.
- B)** Install item (3) with hose clamps starting at left column cylinder (5) and working toward the right column. All excess hose should be at bends & inside overhead assembly.
- C)** Connect item (2) & item (3) to Tee (4).

**IMPORTANT:** All O-ring face seal connections should be torqued to 18-20 ft. lbs.

**NOTE:** Route Power Unit hose inside columns using slots provided at column base, Fig. 11, Fig. 12, and Fig. 13. Route Overhead Hose in column channel on outside of column to inside of column extensions. Attach to column extensions with pipe clamp and route up and thru hole in each end of the overhead.

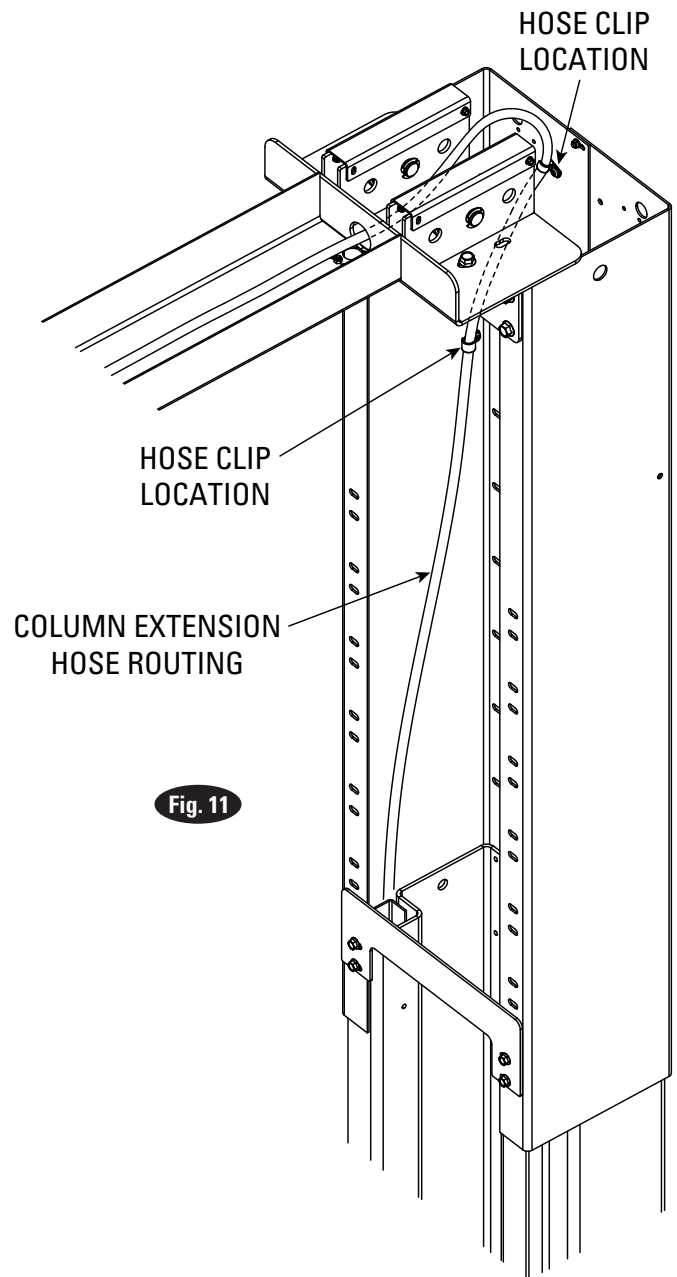
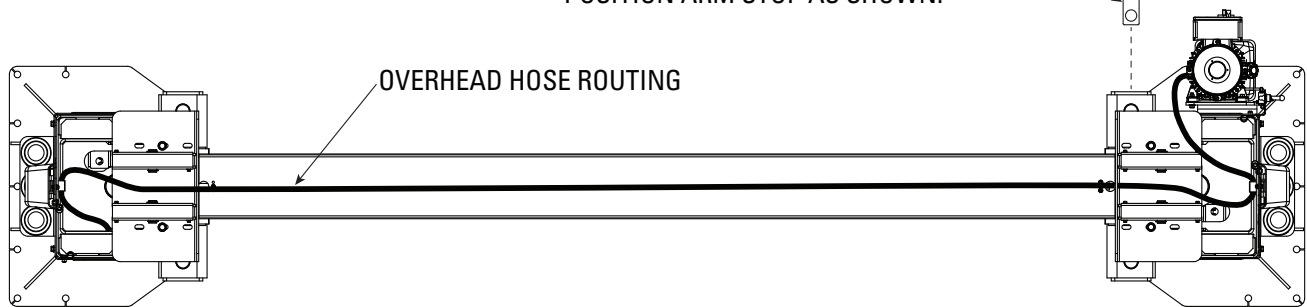
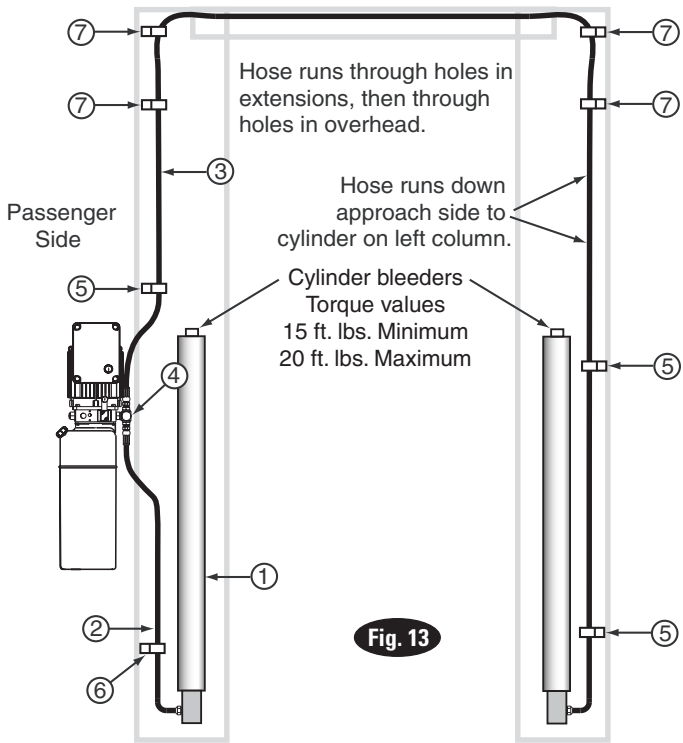

Fig. 11

Fig. 12

ARM STOP (REF FIG. 21) IS LOCATED IN THE YOKE TUBE CLOSEST TO THE POWER UNIT. POSITION ARM STOP AS SHOWN.





**Fig. 13**

ITEM	QTY.	DESCRIPTION
1	2	Hydraulic Cylinder
2	1	Power Unit Hose
3	1	Overhead Hose
4	1	Branch Tee
5	3	Hose Clips(5/8")
5	3	5/16"-18NC x 3/8" lg. PHMS
6	1	Hose Clips(1/2")
6	1	5/16"-18NC x 3/8" lg. PHMS
7	4	Hose Clips(5/8")
7	4	5/16"-18NC x 1/2" lg. PHMS
7	4	5/16"-18NC Nut

**12. Equalizer Cables:** Fig. 15 describes general cable arrangements. It is easier to tie-off lower (short) cable studs first. **Notice**, long cable studs must be located on top, Fig. 14.

- A)** Run cable stud up through the lower tie-off plate, and/or bracket(s), and/or spacer(s) depending on the lift model, Fig. 15.
- B)** Push cable up until stud is above top of carriage Fig. 15.

- C)** Run nylon insert locknut onto studs so that 1/2" extends out from locknut Fig. 15.
- D)** Pull cables back down through carriage Fig. 15.
- E)** Run cable overhead and tie-off top (long) cable studs and torque to about 100 in-lbs., see Fig. 14 & Fig. 15.

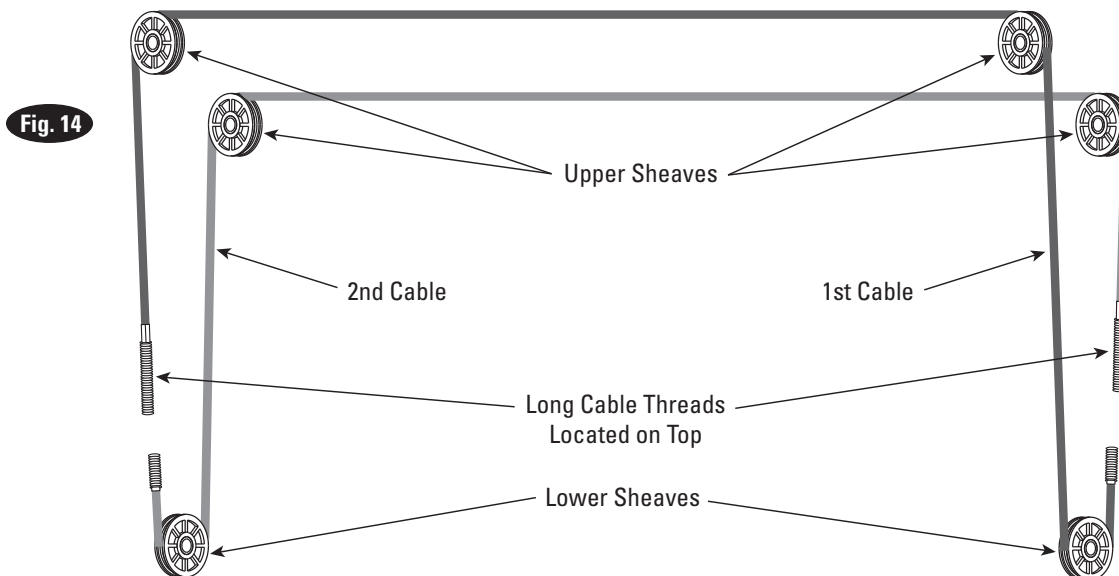

**Fig. 14**

\*\*\*Longer threaded side must always be tie - off at upper tie - off (1 and 1a)  
 \*\*\*Overhead must have matching sheave placement on both sides to be installed correctly

Cable	Height	Stance					
		Narrow (Pin hole to Pin hole 119.375)		Standard (125.375)		Wide (131.375)	
484, standard ceiling	198"	<u>Upper Tie-off</u> 1	<u>Lower Tie-off</u> 3 + 12" spacer	<u>Upper Tie-off</u> 1a	<u>Lower Tie-off</u> 3	<u>Upper Tie-off</u> 1	<u>Lower Tie-off</u> 3
	192"	<u>Upper Tie-off</u> 1	<u>Lower Tie-off</u> 2	<u>Upper Tie-off</u> 1a	<u>Lower Tie-off</u> 3 + 12" spacer	<u>Upper Tie-off</u> 1	<u>Lower Tie-off</u> 3 + 12" spacer
	186"	<u>Upper Tie-off</u> 1	<u>Lower Tie-off</u> 2 + 12" spacer	<u>Upper Tie-off</u> 1a	<u>Lower Tie-off</u> 2	<u>Upper Tie-off</u> 1	<u>Lower Tie-off</u> 2
	180"	<u>Upper Tie-off</u> 1a	<u>Lower Tie-off</u> 2 + 18" spacer	<u>Upper Tie-off</u> 1a	<u>Lower Tie-off</u> 2 + 12" spacer	<u>Upper Tie-off</u> 1	<u>Lower Tie-off</u> 2 + 12" spacer
436, low ceiling	174"	<u>Upper Tie-off</u> 1	<u>Lower Tie-off</u> 3 + 12" spacer	<u>Upper Tie-off</u> 1a	<u>Lower Tie-off</u> 3	<u>Upper Tie-off</u> 1	<u>Lower Tie-off</u> 3
	168"	<u>Upper Tie-off</u> 1	<u>Lower Tie-off</u> 2	<u>Upper Tie-off</u> 1a	<u>Lower Tie-off</u> 3 + 12" spacer	<u>Upper Tie-off</u> 1	<u>Lower Tie-off</u> 3 + 12" spacer
	162"	<u>Upper Tie-off</u> 1	<u>Lower Tie-off</u> 2 + 12" spacer	<u>Upper Tie-off</u> 1a	<u>Lower Tie-off</u> 2	<u>Upper Tie-off</u> 1	<u>Lower Tie-off</u> 2

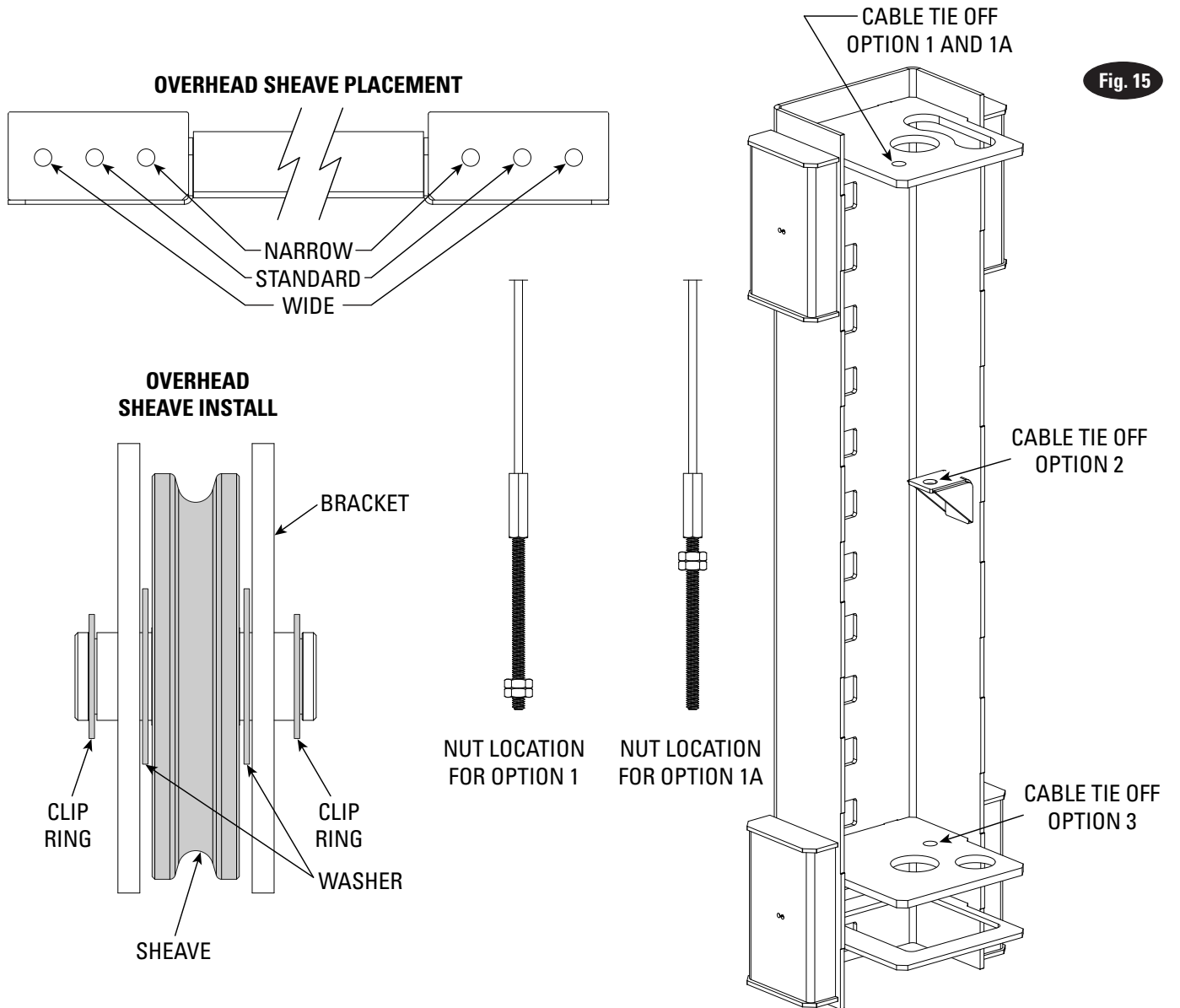

Fig. 15

### 13. Locking Latch & Air Cylinders:

- A)** To install cylinder, first slip dampening spacer over rod with rod in retracted position as shown below, Fig. 16.
- B)** Put locknut on threaded shaft and run it down to the dampening spacer.
- C)** Let rod extend and thread locknut down 1-1/2 more turns.
- D)** Screw Bracket Clevis onto shaft, position, and tighten locknut securely, Fig. 16.
- E)** Slide latch control plate into top cylinder Bracket Clevis.
- F)** Insert Pivot Pin through hole in bracket and Latch Plate. Install one clip ring on each side of Upper Pin.
- G)** Extend cylinder where column Pivot Bracket is to be mounted.

- H)** Slide one side of lower Pivot Pin (pre-installed & fixed in cylinder) into one half of the column Pivot Bracket. Install Pivot Bracket into column using (2) 1/4"-20NC x 3/8" lg. PHMS, Fig. 16.
- I)** Install other half of Pivot Bracket the same way.
- J)** Install air lines from main air supply (with filter) to latch release air valve. Install air line from latch release air valve to union tee then to the right column air cylinder.
- K)** Install air line from union tee to left column air cylinder, Fig. 18.
- L)** Route airlines along and wire tie to the hydraulic hoses.

**Note:** Absence of air filter/regulator/lubricator will void the warranty on all pneumatic components.

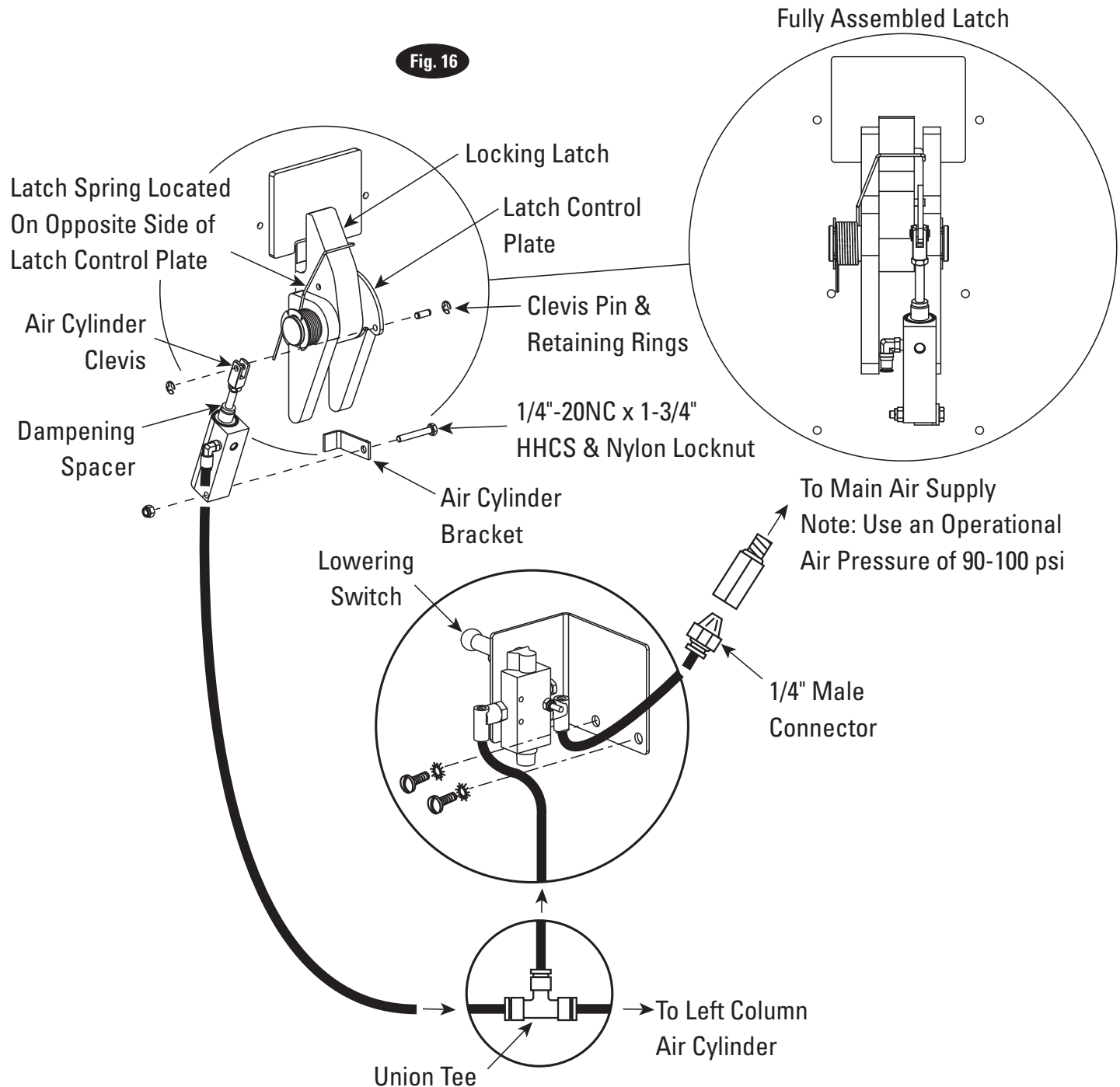

**Note:** Cut provided tubing with sharp blade to length as required. Tubing must be cut square with no burrs. To assemble air line tubing into fitting, use firm, manual pressure to push tubing into fitting until it bottoms, see below. If removal of the air line tubing from the fitting is ever required, hold Push Sleeve in (against fitting) and at the same time, pull out on tubing.

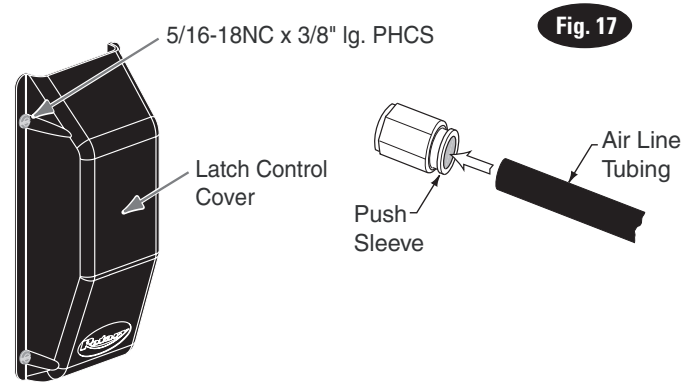

**Fig. 17**

**Locking Latch Engagement Test:**

- A)** Raise carriages past the first latch position and then lower onto latches.
- B)** Check that the latches have fully engaged when the release switch is not depressed.
- C)** Raise carriages fully off latches. Now depress release switch and check that the latches have fully disengaged.
- D)** Check for air leaks, make necessary adjustments or repairs if required.
- E)** Install latch covers with 5/16"-18NC x 3/8" lg. PHCS, Fig. 17.

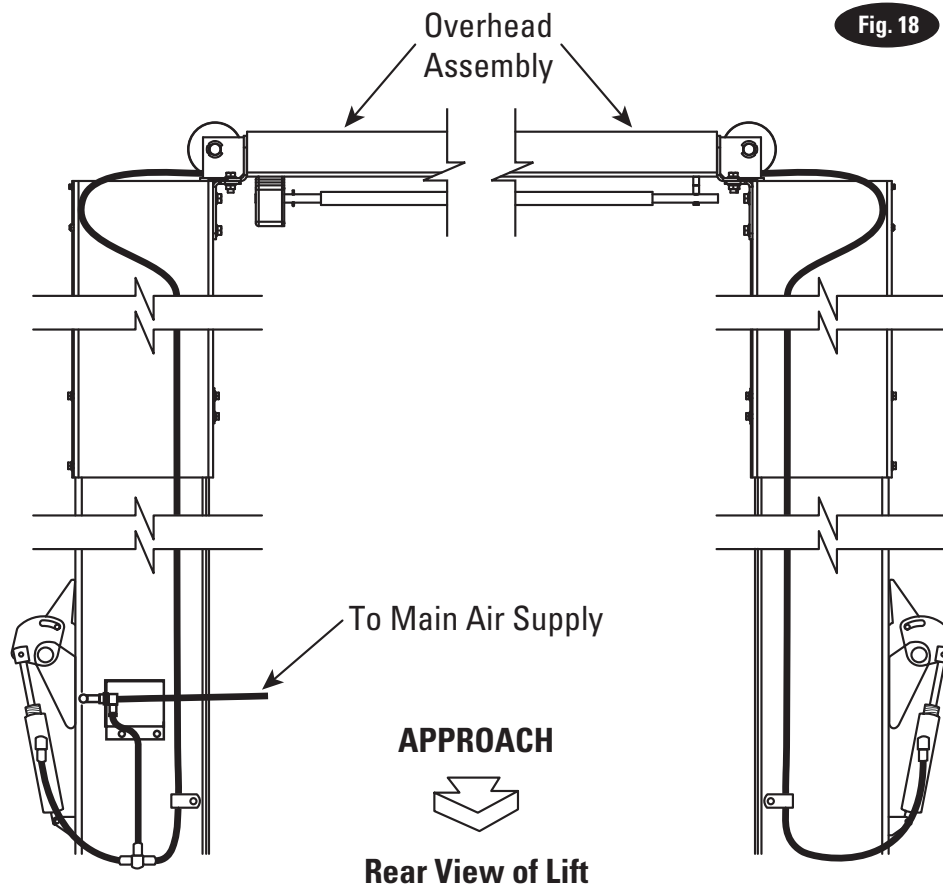

**Fig. 18**

**14. Electrical:** Have a certified electrician run appropriate power supply to motor, Figs. 19 and 20. Size wire for 20 amp circuit. See Motor Operating Data Table.

**CAUTION** Never operate the motor on line voltage less than 208V. Motor damage may occur.

**IMPORTANT:** Use separate circuit for each power unit. Protect each circuit with time delay fuse or circuit breaker. For single phase 208-230V, use 30 amp fuse. For wiring see Figs. 19 and 20. All wiring must comply with NEC and all local electrical codes.

**Note:** 60Hz. single phase motor **CAN NOT** be run on 50Hz. line without a physical change in the motor.

**15. Overhead switch:** Check overhead switch assembly to assure that switch bar is depressing switch plunger sufficiently to actuate the switch. The overhead switch is wired normally open, see Fig. 20. Lift will not operate until weight of switch bar is depressing switch plunger. Verify that Power Unit stops working when switch bar is raised, and re-starts when the bar is released.

**CAUTION** When bleeding, hold a shop cloth over bleeder screw to buffer the air and fluid while bleeder-valve is open.

**16. Oil Filling & Bleeding:** Use Dexron III ATF, or Hydraulic Fluid that meets ISO 32 specifications. Remove fill-breather cap, Fig. 20. Pour in (8) quarts of fluid. Start unit, raise lift about 2 ft. Open cylinder bleeders approx. 2 turns, Fig. 13.

Close bleeders when fluid streams. Torque values for the bleeders are 15 ft. lb. minimum and 20 ft lb. maximum. Fully lower lift. Add more fluid until it reaches fill line on the tank. System capacity is (14) quarts. Replace fill-breather cap.

**CAUTION** If fill-breather cap is lost or broken, order replacement. Reservoir must be vented.

## Single Phase Power Unit

MOTOR OPERATING DATA TABLE - SINGLE PHASE	
LINE VOLTAGE	RUNNING MOTOR VOLTAGE RANGE
208-230V 50Hz.	197-253V
208-230V 60Hz.	197-253V

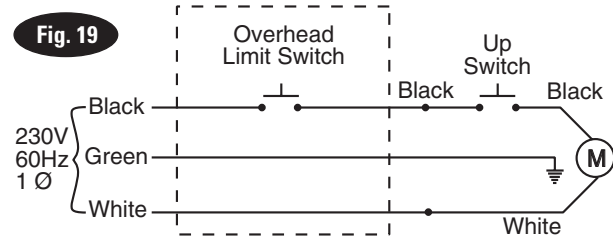

**Note:** 60Hz. Single phase motor **CAN NOT** be run on 50Hz. line without a physical change in the motor.

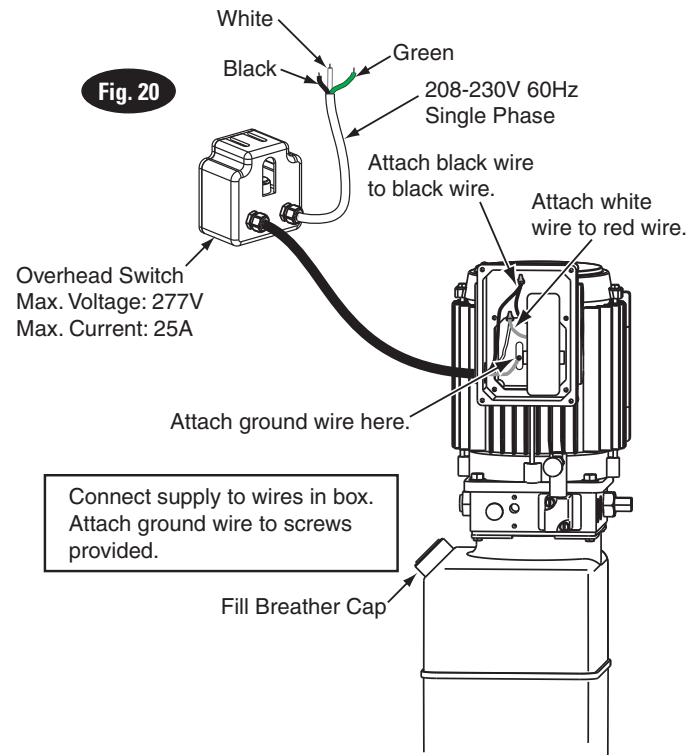

**NOTE:** Assure cord used for connection between the overhead switch and power unit is of the type specified in:

UL201, Sections 10.1.1.3 & 10.1.1.4

(Example: SO, G, STO) Size for 25 amp circuit. See UL 201, Section 15 for proper wiring requirements for this connection.

**17. Arm Restraints & Superstructure:**

Before installing arms, grease arm pins and holes with lithium grease. Slide arm onto yoke and install the arm pins.

**Note:** Install Arm Stop only in the yoke tube closest to the Power Unit as shown in Fig. 21.

Install arm restraint gear over pin and into the slot in the arm pin ensuring the side of the gear marked TOP is facing upward. Fig. 22.

**Fig. 22**

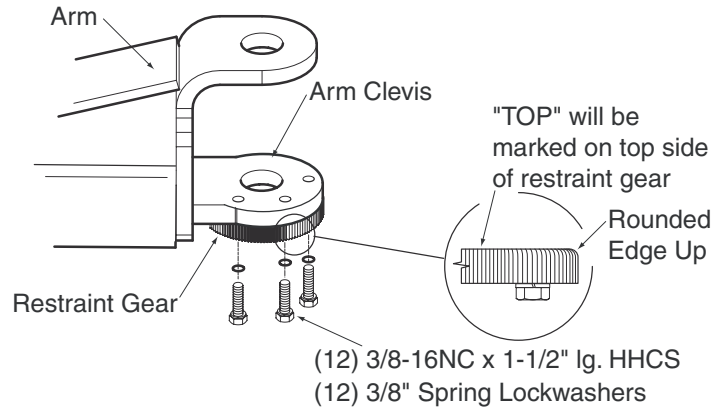

**Fig. 21**

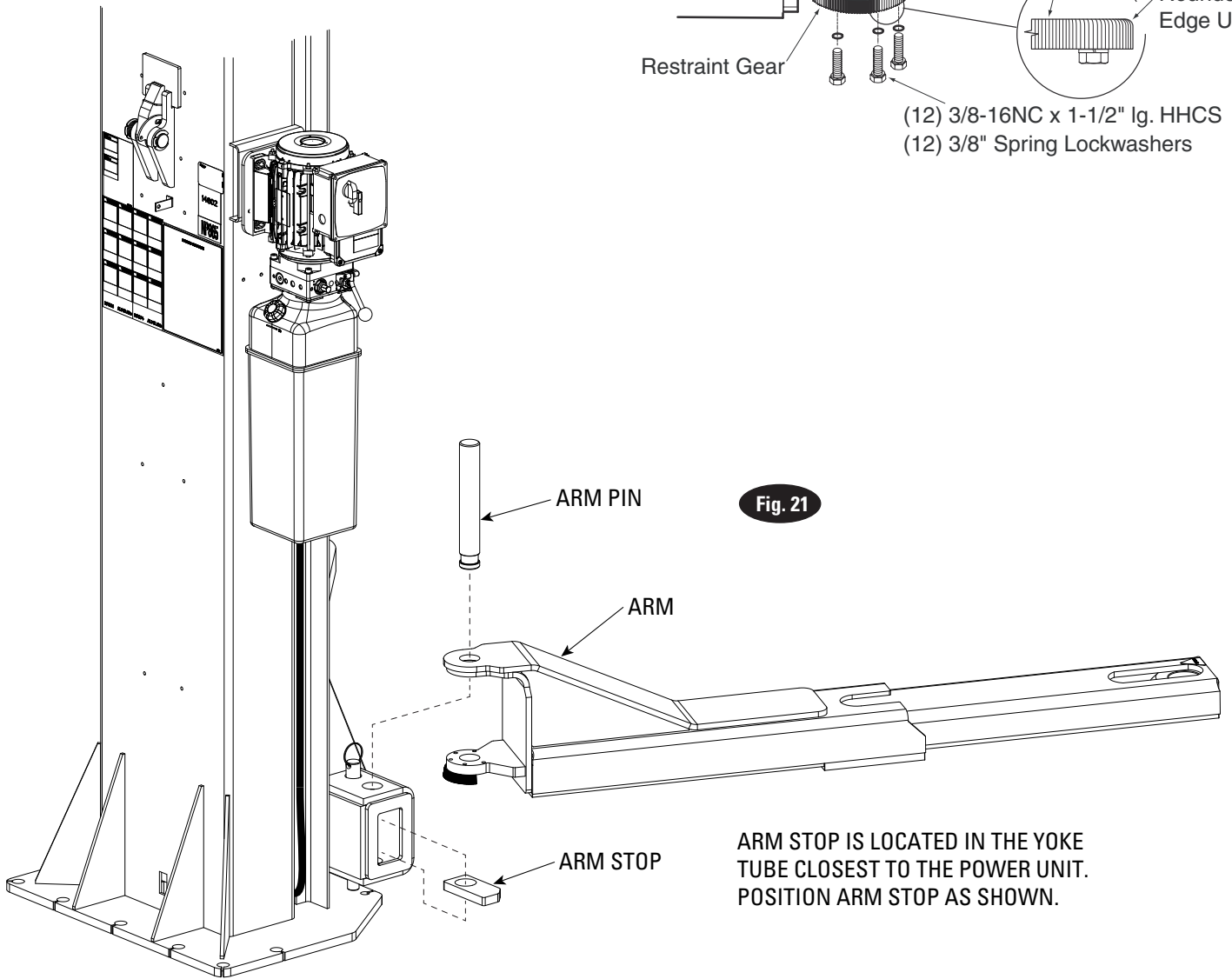

After installing arm pin, torque the three Restraint Gear bolts to 30-34 Ft-Lbs. Let the Gear Block down allowing the teeth of the Restraint Gear and Gear Block to mesh together, Fig. 24.

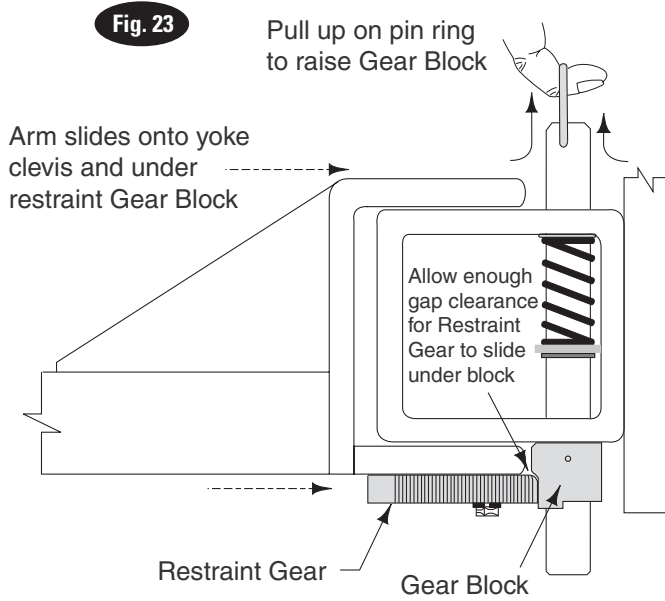

**Note:** Pin, Ring, Spring and Gear Block are pre-assembled at factory. No set up required.

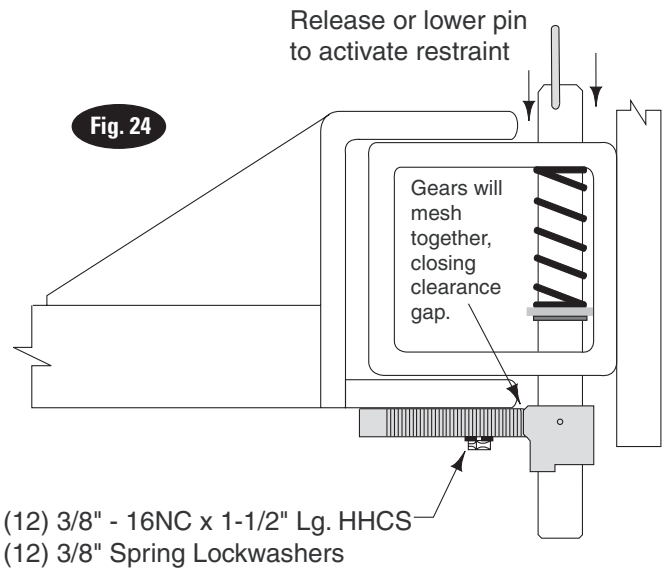

**Note:** To check operation of arm restraints, raise carriage 1" min. from full down position. Pull up on pin-ring and adjust arms to desired position. To engage restraint, let pin-ring down allowing gear teeth to mesh together. It may be necessary to rotate arm slightly to engage gear teeth.

**18. Wheel Spotting Dishes:** Position wheel spotting dishes as described in Fig. 1. Drill (4) 3/8" holes 2 1/2" deep in concrete floor using holes in wheel spotting dishes as guide. Drive all anchors, provided, into concrete to secure dish.



### 19. Door Bumper Installation:

1) Press bumpers on column edge and carriage, Fig. 25.

**Note:** Door Bumpers may need to be installed in different areas depending upon type(s) of vehicles used. The above installation is the most recommended.

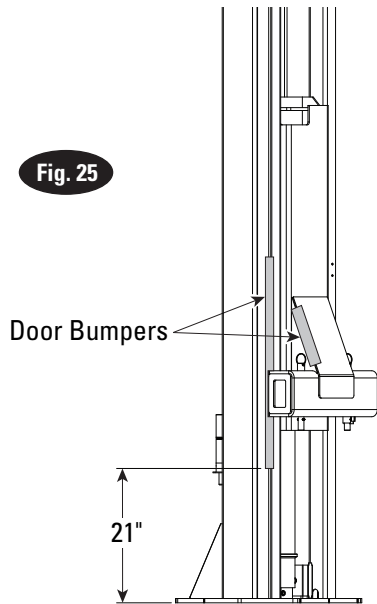

**20. Pressure Test:** Run lift to full rise and keep motor running for 5 seconds. Stop and check all hose connections. Tighten or reseal if required. Repeat air bleeding of cylinders.

**21. Final Adjustments:** Raise lift to check equalizer cable tension. Below carriage, grasp adjacent cables between thumb and forefinger, with about 15 lbs. effort you should just pull the cables together. Adjust at upper tie-offs, Fig. 15.

**22. Decal Location:** Install enclosed pinch point decals. Place (1) decal on each column, Fig. 26.

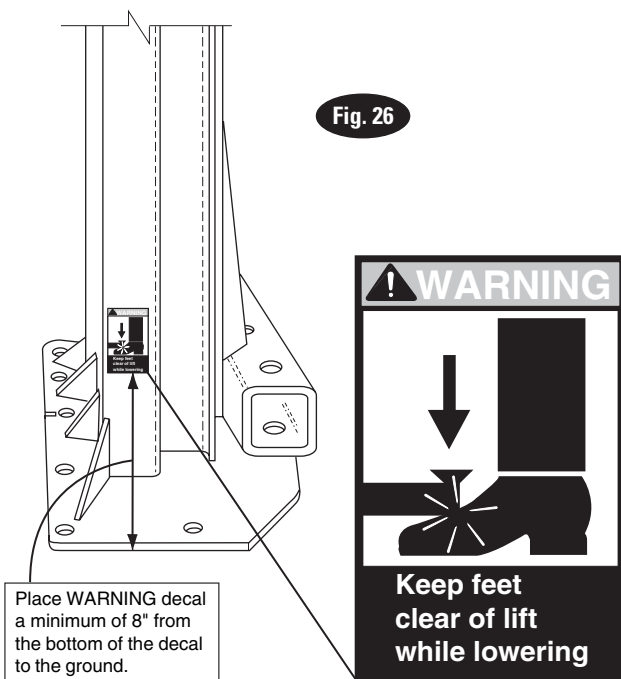

**23. Adapter Rack:** Install adapter rack, Fig. 27. Place extension in racks.

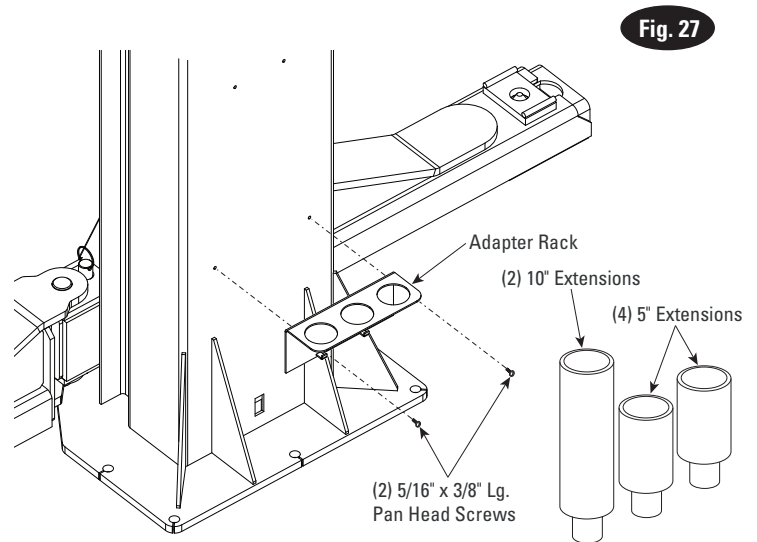

**! WARNING** (2) qty. 10" adapter extensions and (4) qty. 5" adapter extensions are supplied with each lift. These extensions should not be stacked more than 15" high.

**24. Upon completion** of the assembly of the lift, the lift is to be operated to assure proper function. Observe for locks operating in all locking positions, each side lifts equally, hydraulics do not leak, all electrical controls function as labeled, all pneumatics are functional and leak free, ramps rotate freely (if applicable), and proper clearances with all items in bay have been maintained.

Operate the lift with a typical vehicle and observe to assure the same items for proper functioning.

# SP016 - SPO20 2-Post DC Installation

Recommended Battery Specifications		
	Normal Operation and Life	High Use (15 minutes or less between lift cycles) or increase in life under normal use
Battery Type	Standard Lead Acid	Absorbed Glass Mat (AGM) Technology
Voltage	12V	12V
Size	Group 24	Group 24
Cold Cranking Amps	525	710
Terminal Location	Top	Top

**Note:** If a single battery fails during use the system should be evaluated to determine if the second battery should be replaced at the same time to avoid down time at a later date due to issues with the battery.

## 25. Power Unit:

A) First, install (1) star washer onto one of the (4) 5/16"-18NC x 1" long HHCS. *This is very important for grounding.*

B) Put the (4) 5/16"-18NC x 1" HHCS thru holes in the power unit bracket and splash shield using push-nuts to hold in place, Fig. 28.

C) Mount power unit with motor up to the column bracket and install (2) 5/16" star washers and (4) 5/16" nuts.

## 26. DC Control Cabinet:

A) First, remove front plastic covers and lower cover, Fig. 29, and set aside to be reinstalled later.

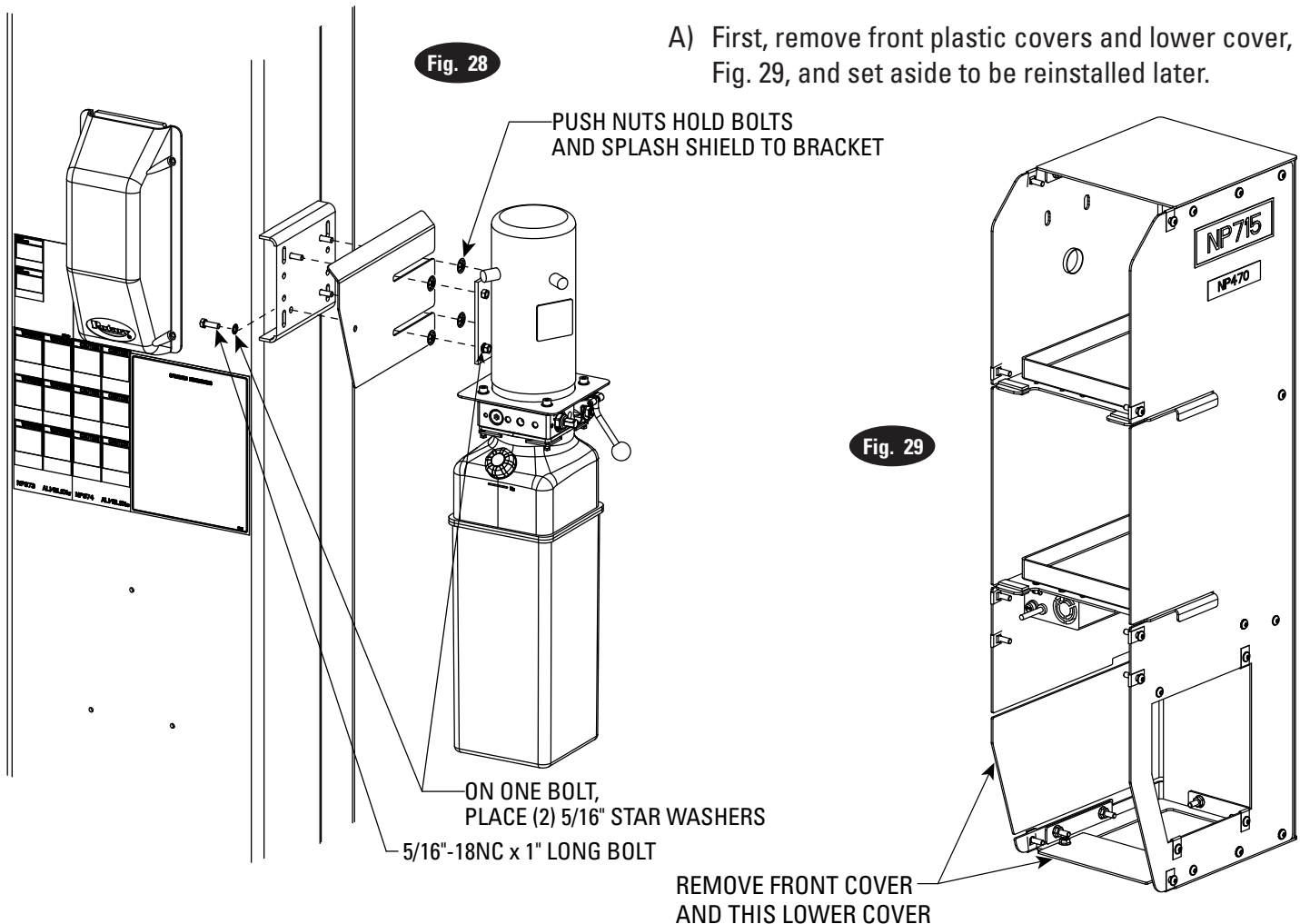

B) Install included 3/8 NPT strain relief and nut to the back of the cabinet and route the FA9190-6 over head switch cable through the strain relief, Figure 30. The FA9190-6 overhead switch cable is shipped attached to the grounding bolt inside the DC control cabinet.

**Fig. 30**

INSTALL 3/8 NPT STRAIN RELIEF AND NUT TO THE BACK OF THE CABINET AND ROUTE FA9190-6 OVERHEAD SWITCH CABLE THROUGH THE STRAIN RELIEF (ATTACHED TO THE MOTOR CONTACTOR)

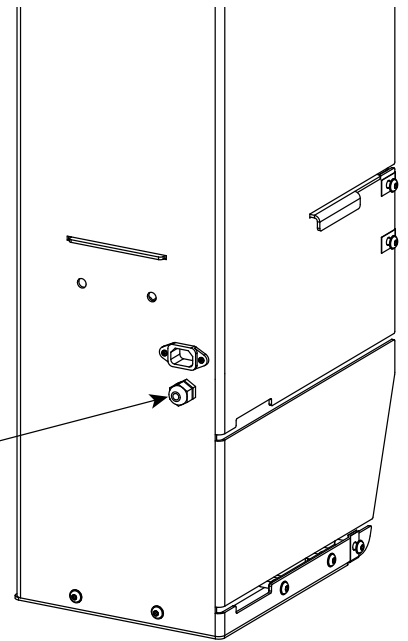

C) Attach battery cabinet mounting bracket to the cabinet with (2) 5/16"-18NC x 1" lg. flange head cap screws and nuts as shown, Figure 30a.

**Fig. 30a**

(2) 5/16"-18NC HEX FLGD WZLOCK NUT

BATTERY CABINET MOUNTING BRACKET

(2) 5/16"-18NC x 1" Lg. HEX FLGD WZLOCK HHCS

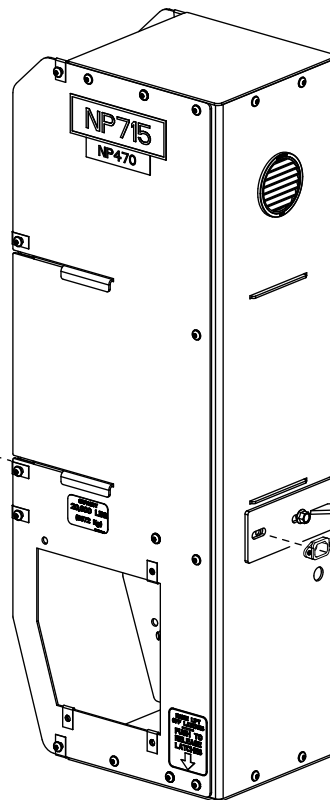

D) Mount DC control cabinet by sliding slots around the power unit bracket flanges, Figure 31 and 32.

Fig. 31

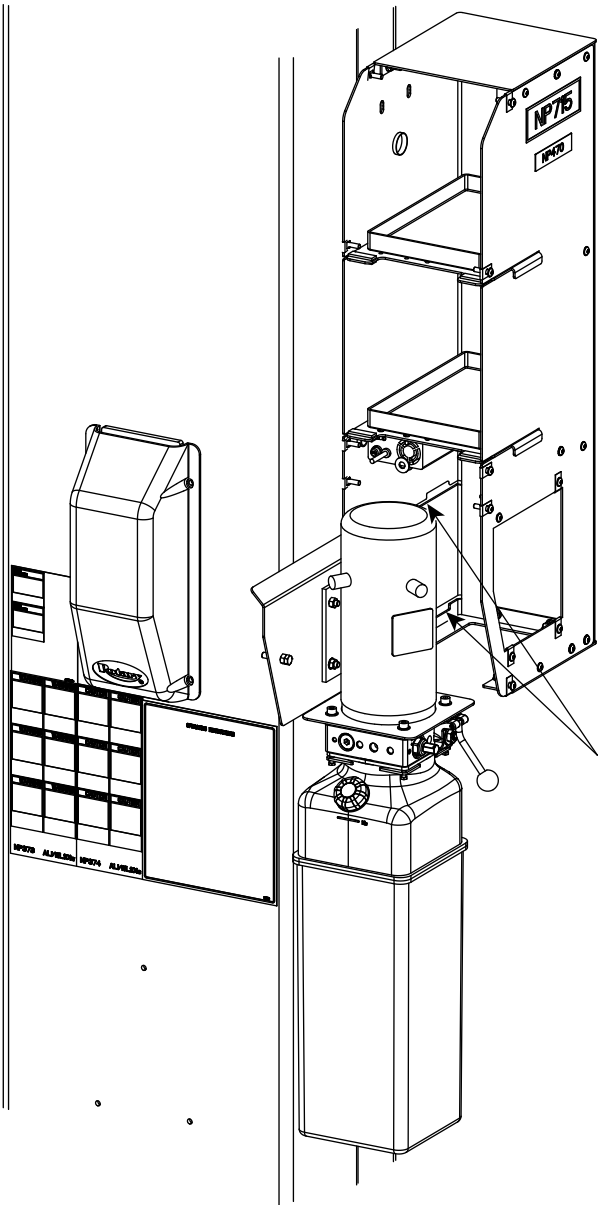
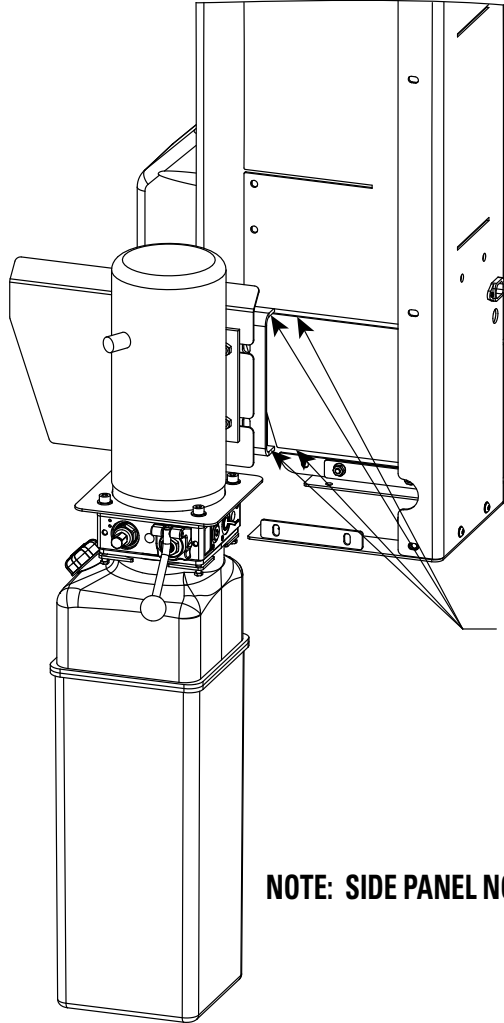

Fig. 32



MOUNT CABINET  
SO THAT SLOTS  
SLIDE AROUND  
POWER UNIT  
BRACKET FLANGES

**NOTE: SIDE PANEL NOT SHOWN**

## 27. DC Control Cabinet Top Bracket:

- A) Secure top of DC control cabinet by mounting bracket to the top of the column as shown in fig. 33.
- B) Fasten the bracket to the column, to the extension, using the included hardware as shown in fig. 33.

- C) Mount the bracket to the side of the cabinet using the included hardware as shown in fig. 33.
- D) The DC control cabinet should rest against the side of the column.
- E) Fasten the included 5/16"-18NC x 1-1/2" full thread bolt and (2) 5/16"-18NC hex nuts to the splash shield as shown in figures 34 & 35.

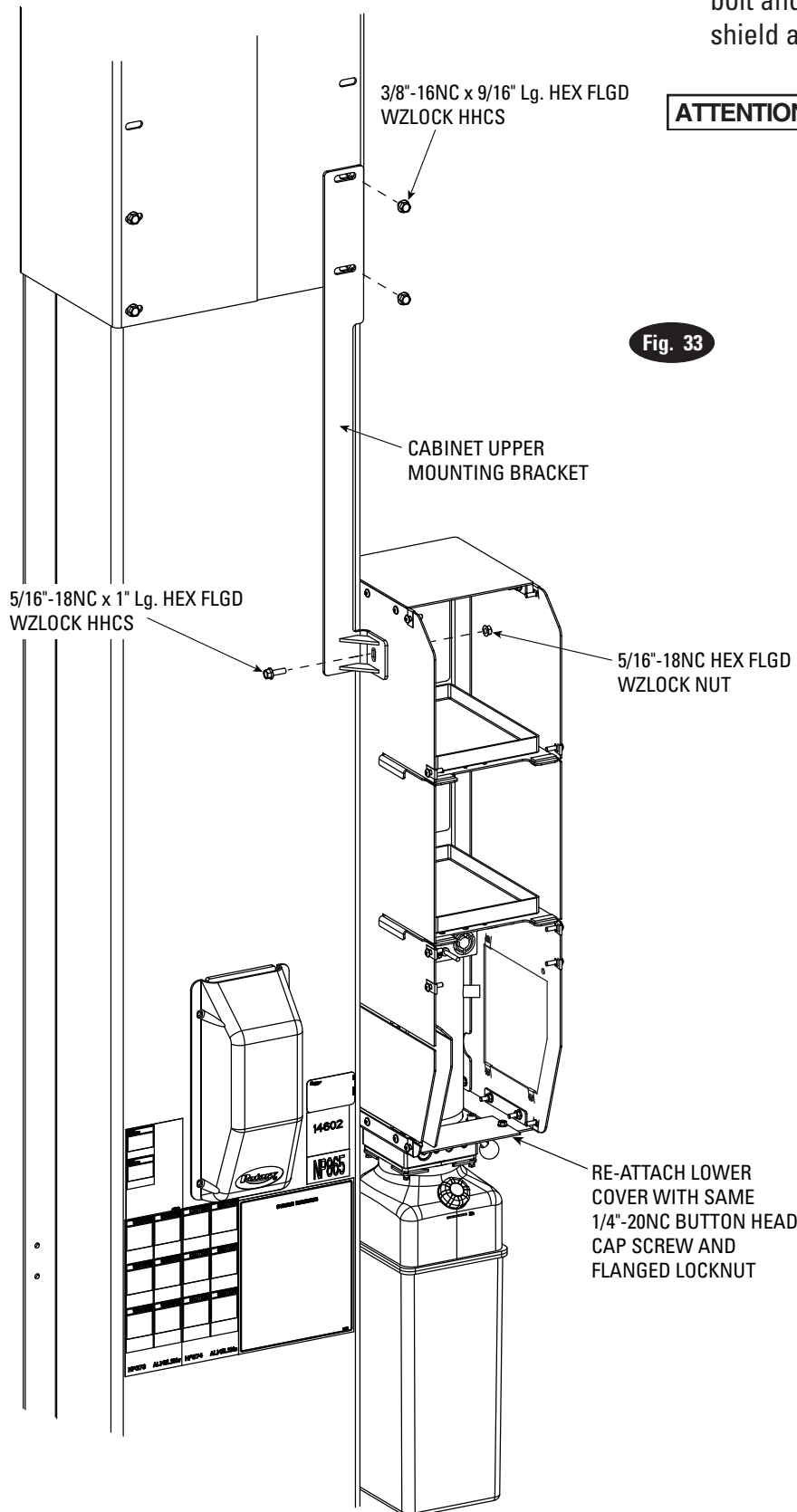

**ATTENTION**

Do not overtighten the bolt and push the enclosure outward.

Fig. 33

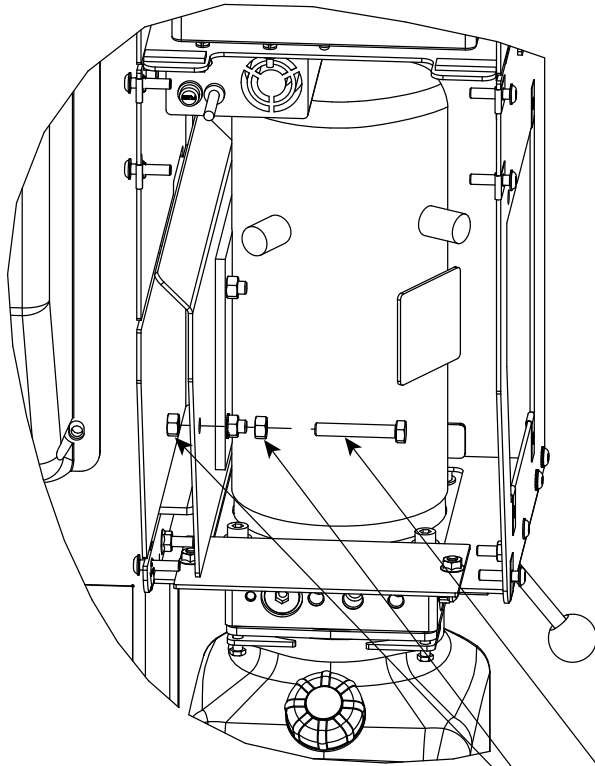
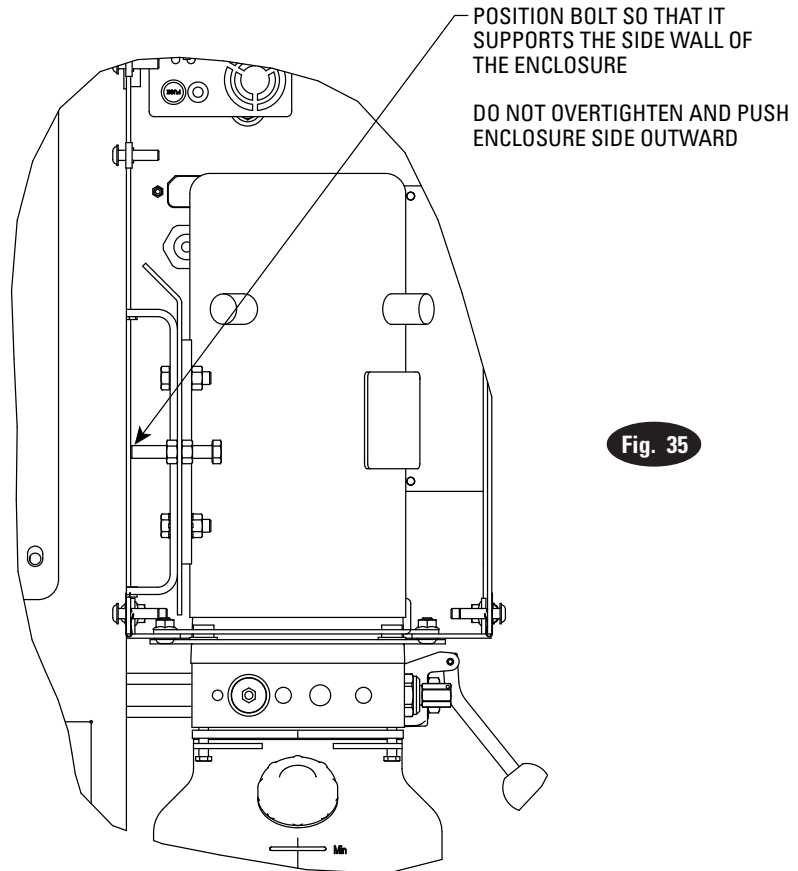

Fig. 34

5/16"-18NC x 1-1/2" FULL THREAD BOLT

5/16"-18NC HEX NUTS



POSITION BOLT SO THAT IT SUPPORTS THE SIDE WALL OF THE ENCLOSURE

DO NOT OVERTIGHTEN AND PUSH ENCLOSURE SIDE OUTWARD

Fig. 35

## 28. DC Control Cabinet Bottom Bracket:

A) Secure bottom of DC control cabinet by mounting it to the side of the column using the included brackets. Fasten the back side of the cabinet to the column using the (2) angle brackets.

B) Fasten the two brackets to the column and DC control as shown below, Figure 36.

C) Re-attach the lower cover with the same 1/4"-20NC button head cap screws and flanged locknuts shown in fig. 33.

D) Attach the side panel using parts from the box labeled "FA9190" following the included instructions.

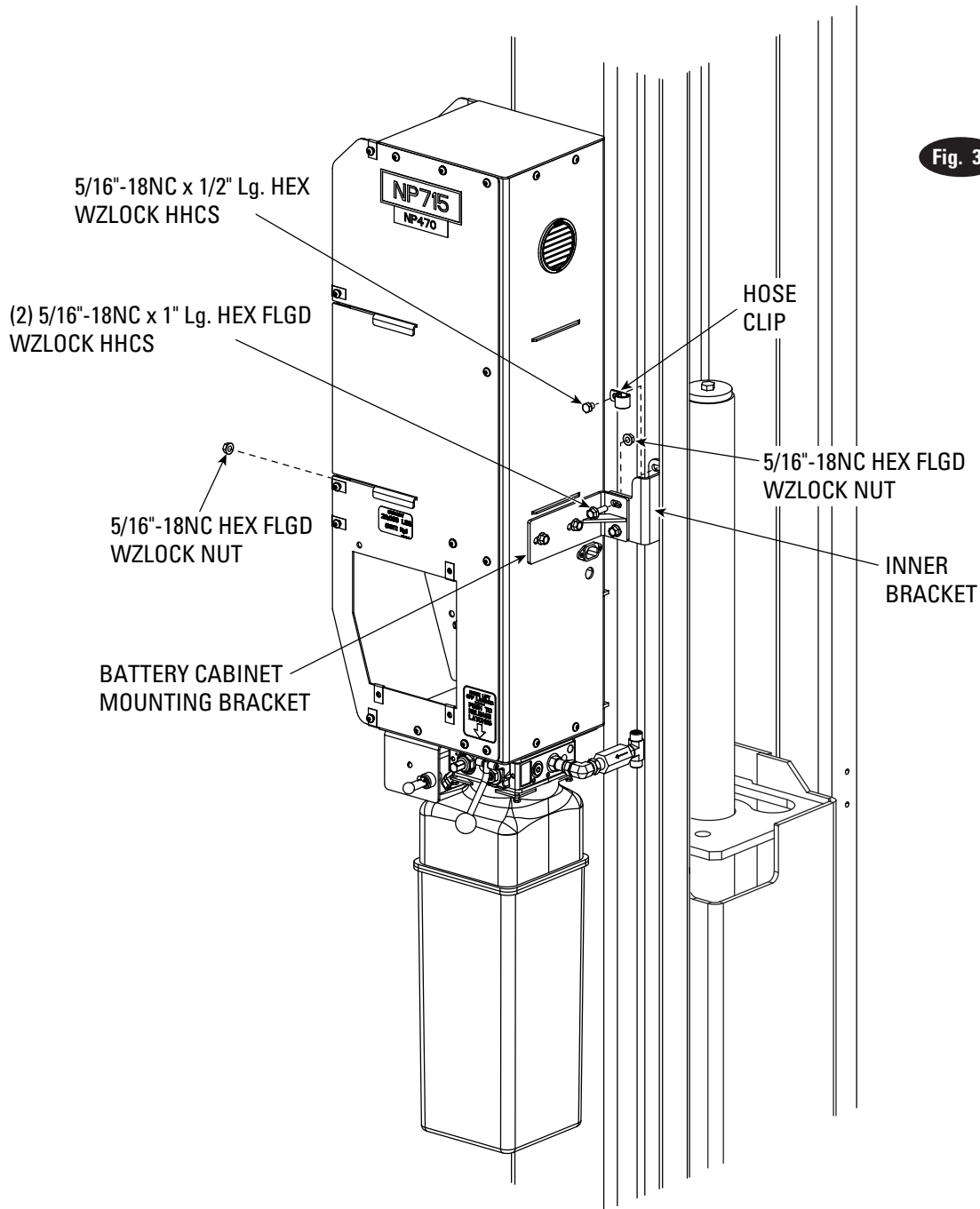

## 29. Lowering Valve Bracket:

- A) First, attach brass filter and swivel elbows to the air valve, Figure 36a.
- B) Mount the air valve to the lowering valve bracket using the included #8-32NC x 1-1/2" screw, washer and nut. Attach the handle to the air valve lever.
- C) Next, attach the lowering valve bracket to the underside of the control cabinet, see Figure 36a. Fasten the bracket using the included (2) 1/4" -20NC x 1/2" long button head cap screws and (2) 1/4" -20NC flanged locknuts, Figure 36a.
- D) Finally, fasten the NP280 label to the front of the bracket and connect the shop air supply with included in-line filter to latch release air valve brass elbow fitting, Figure 36a.
- E) Run air line from elbow shown in Figure 36a to the lift using 1/4" polypropylene tubing with 300 psi working pressure. Run the air line through the 2" PVC pipe chase and connect to air-line attached to the vertical hose using push union.

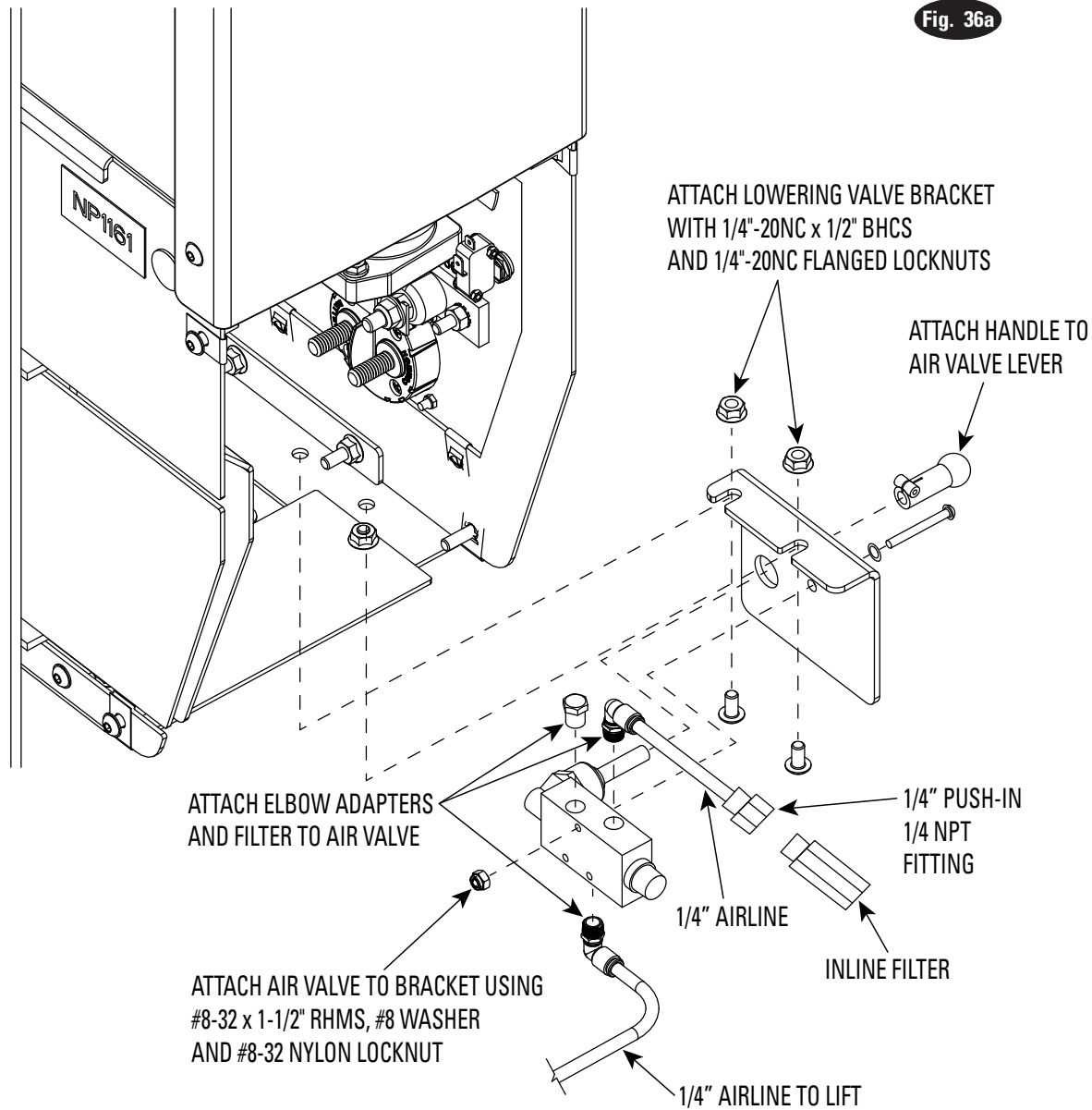



### 30. DC Control Cables:

**CAUTION** Before making electrical connections, verify the red disconnect switch on the side panel is in the **OFF** position.

A) Fasten the “A” labeled terminal end of the FA9190-8 cable to the positive terminal of the motor, Fig. 37 and Fig. 37a. Fasten the other end of FA9190-8 cable to the empty motor contact terminal, Fig. 37b.

B) Fasten the “B” labeled terminal end of the FA9190-12 red cable to the “Battery” side of the disconnect switch. (Note: FA9190-12 black cable wired to ground from charger), Fig. 37b.

C) Fasten the “C” labeled terminal end of the FA9190-6 red cable to the small right terminal contactor, Fig. 37b. (Note: FA9190-6 black cable wired to ground.)

D) Attach battery post connectors to the positive and negative posts on both the top and bottom batteries, Fig. 37.

E) Fasten the “D” labeled terminal end of the FA9190-9 cable to the positive post of the top battery, Fig. 37. The FA9190-9 cable is shipped connected to disconnect.

F) Fasten the “E” labeled terminal end of the FA9190-7 cable to the negative post of the top battery, Fig 37.

G) Fasten the “F” labeled terminal end of the FA9190-7 cable to the positive post of the bottom battery, Fig 37.

H) Fasten the FA9190-5 black cable to the negative post of the bottom battery, terminal “G”, Fig. 37. The opposite end is shipped connected to ground.

I) Fasten the “H” labeled terminal end of the FA9190-10 cable to the negative post of the bottom battery, terminal “H”, Fig. 37. Fasten the other end of the FA9190-10 cable to the negative motor terminal, Fig. 37a. **CAUTION** This step must be completed last.

**CAUTION** When removing batteries always disconnect black FA9190-10 ground cable first.

J) Re-attach top and bottom cover, Fig. 38.

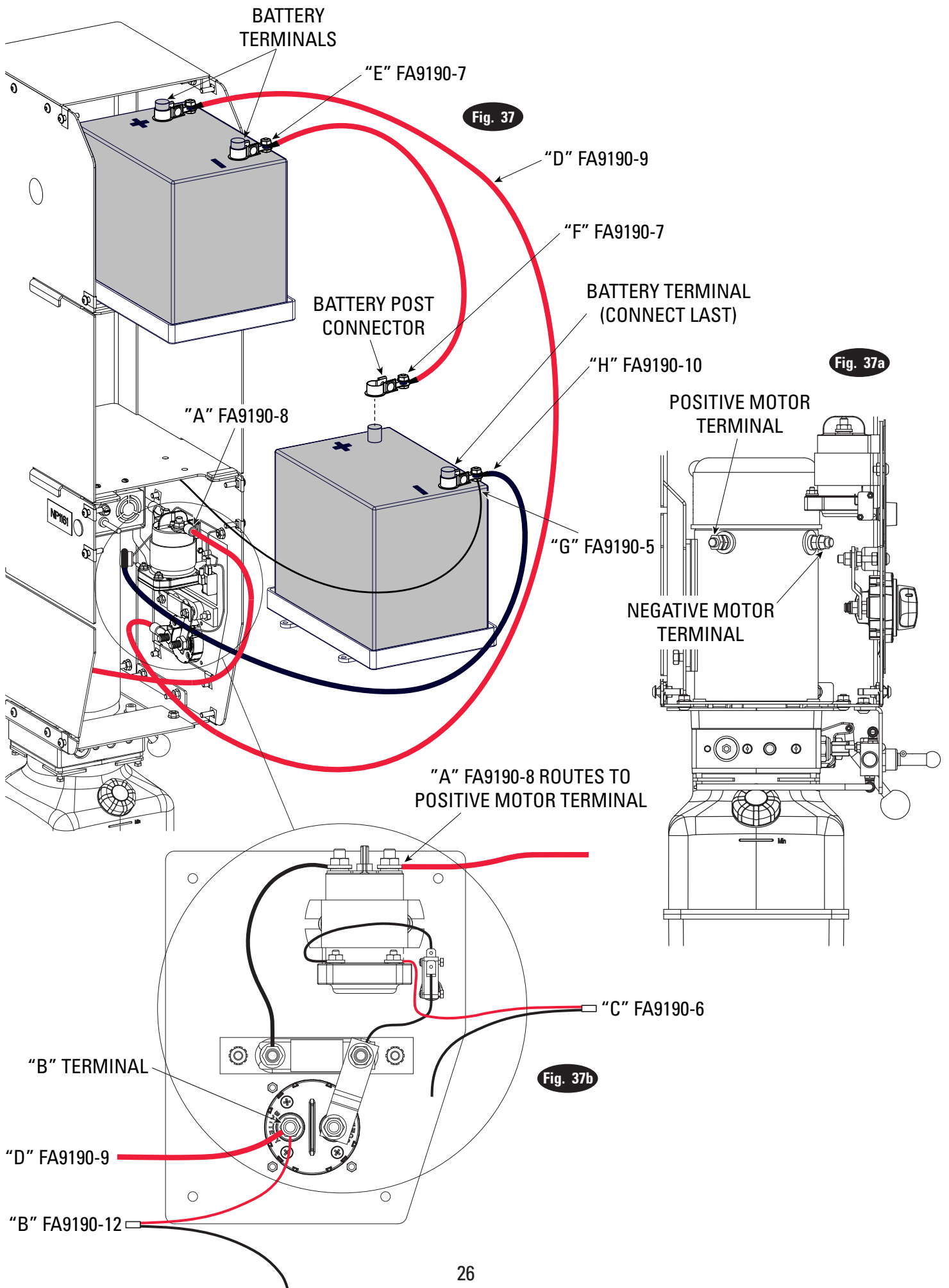

### 31. Hydraulic Fittings and Flow Control:

A) Attach the hydraulic fittings and flow control as shown in the single phase power unit installation, Fig. 10.

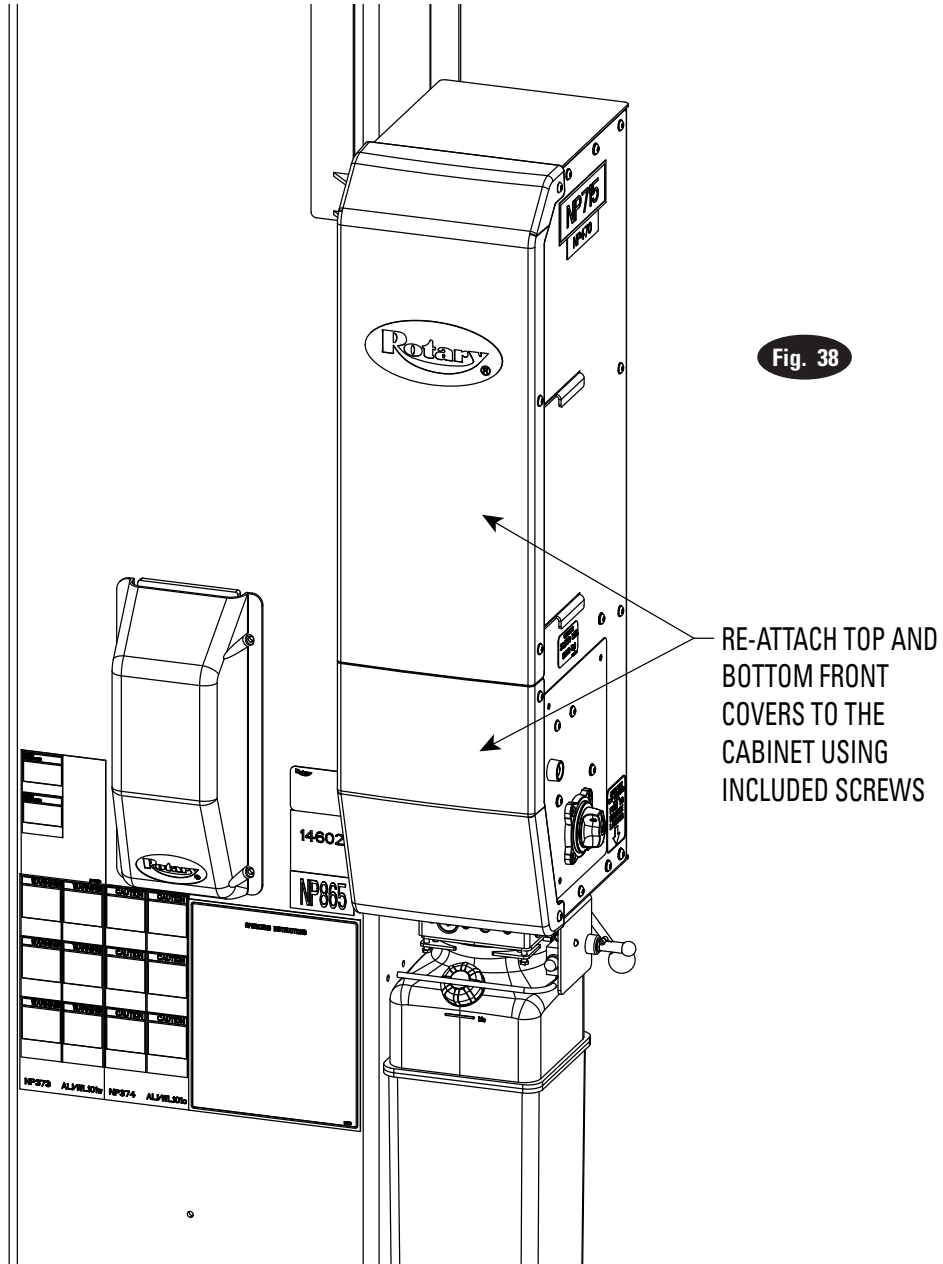

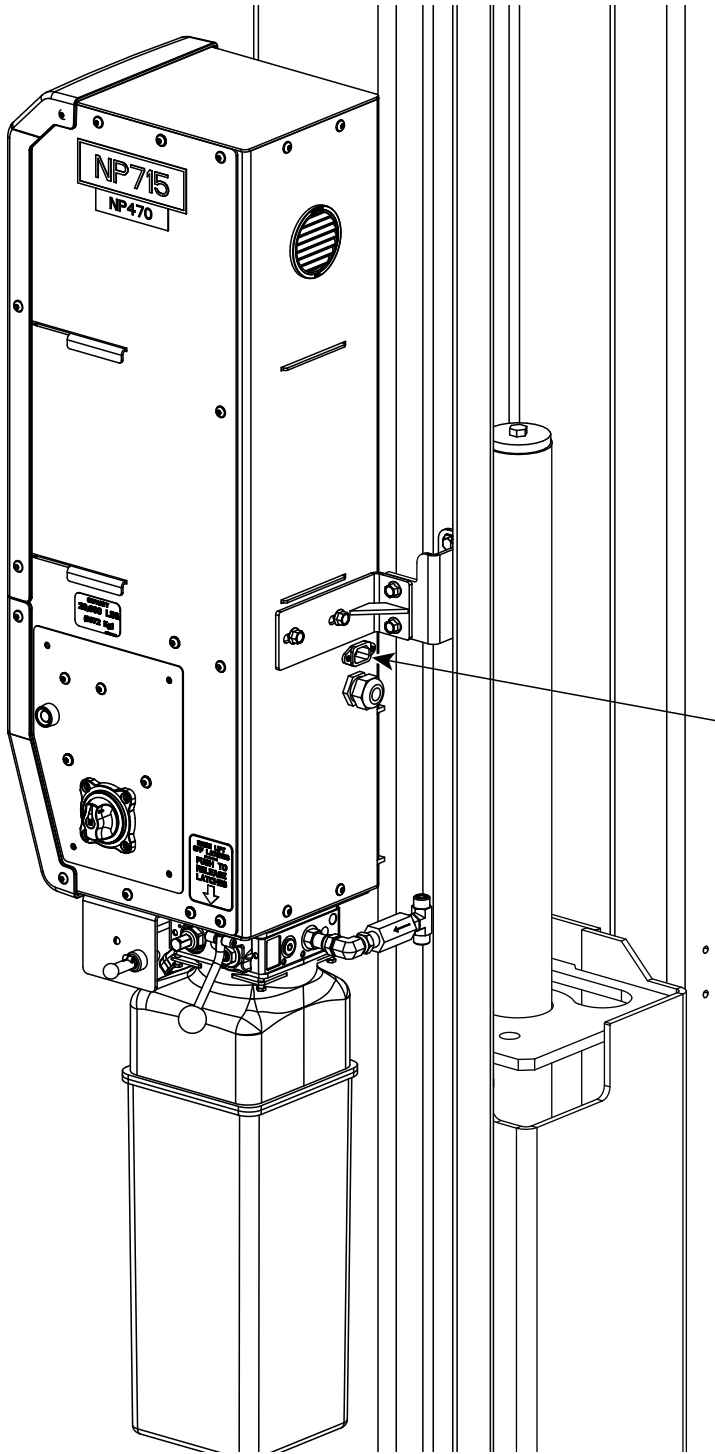

Fig. 39

PLUG CHARGER CABLE INTO RECEPTACLE AND ROUTE CHARGER CABLE AND OVERHEAD SWITCH CABLE TO THE TOP OF THE EXTENSION WITH OVERHEAD HOSE USING WIRE TIES

### **32. Charger Cable & Overhead Switch Cable:**

- A) Plug the male end of the 10 foot charger cable into the receptacle on the back of the DC control cabinet.
- B) Route the charger and overhead switch cable to the top of the power unit column extensions by wire tying them to the overhead hose.

**33. Overhead Switch:** Connect the overhead switch cable to the overhead switch using the included wire nuts.

### **34. Receptacle:**

- A) Mount the receptacle box to the extension directly above the DC control cabinet with the included #12-24NC x 3/4" long pan head machine screws and nuts, Figure 40. Be sure to mount #12 star washers to one mounting screw as shown in Figure 40. This is very important for grounding.
- B) Remove the hole punch covering the hole in the receptacle box than lines up with the hole in the extension. Mount the included 1/2" cord grip thru the hole in the extension and receptacle box.
- C) Mount the included ground wire hook terminal using the included green self-tapping ground screw through the grounding hole in the receptacle box.
- D) Fasten the receptacle to the receptacle box cover with the included fastener and the cover to the box with the included fasteners. The ears on the top and bottom of the receptacle may need to be removed to allow it to fit inside the cover properly. Fasten the tinned end inside the ground terminal of the receptacle.

**35. Electrical:** Have a certified electrician run appropriate power supply to the 120 volt receptacles mounted at the top of the lift.

LIFT ELECTRICAL INPUT: 110-120 Volt, 60 Hz, 3.15 Amps

**Note: A separate circuit is not required for each ShockWave DC powerunit.**

**CAUTION: Never operate the motor on line voltage. Motor damage may occur.**

**36. Laser Spotter:** Mount the laser using the instructions included with the laser spotting kit.

### **37. Plug-in Laser and Charger:**

- A) Plug the laser into the bottom receptacle and wire tie it to the receptacle box, Figure 40.
- B) Plug the charger cable into the top receptacle. Check to make sure the charger lights are on. If charger lights are not on, flip switch on back of charger.

**38. Close DC Control Cabinet:** Re-attach the front plastic covers to the DC control cabinet using the same button head cap screws, Figure 38.

Fig. 40

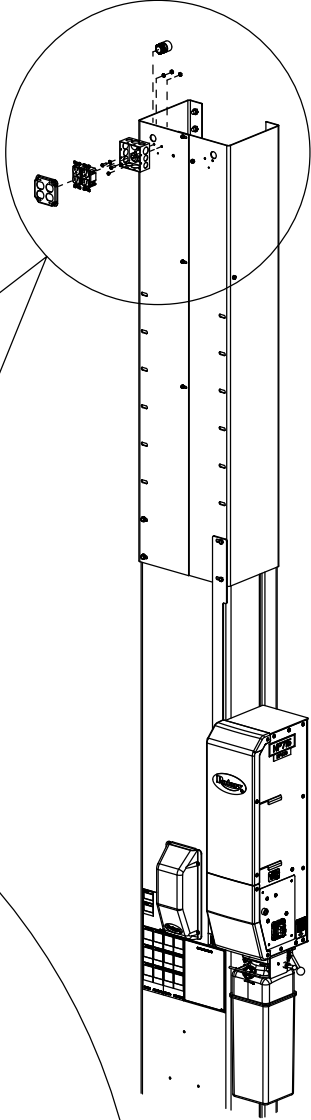

MOUNT RECEPTACLE BOX TO POWER UNIT COLUMN WITH INCLUDED #12-24NC X 3/4" LONG PHMS, AND #12-24NC NUTS. MOUNT #12 STAR WASHERS WITH ONE MOUNTING SCREW, AS SHOWN

MOUNT THRU HOLE IN EXTENSION PUNCH OUT HOLE IN RECEPTACLE BOX THAT LINES UP WITH HOLE IN EXTENSION

PLUG CHARGER CABLE INTO TOP RECEIVER

PLUG THE LASER IN LOWER RECEPTACLE  
WIRE TIE TO RECEPTACLE BOX

FASTEN GROUND WIRE TO RECEPTACLE AND GROUND SCREW



**Installer:** Please return this booklet to literature package, and give to lift owner/operator.

***Thank You***

**Trained Operators and Regular Maintenance Ensures Satisfactory Performance of Your Rotary Lift.**

**Contact Your Nearest Authorized Rotary Parts Distributor for Genuine Rotary Replacement Parts. See Literature Package for Parts Breakdown.**

**Rotary World Headquarters**

2700 Lanier Drive  
Madison, IN 47250, USA  
[www.rotarylif.com](http://www.rotarylif.com)

**North America Contact Information**

Tech. Support:  
p 800.445.5438  
f 800.578.5438  
e [userlink@rotarylif.com](mailto:userlink@rotarylif.com)  
Sales:  
p 800.640.5438  
f 800.578.5438  
e [userlink@rotarylif.com](mailto:userlink@rotarylif.com)

**World Wide Contact Information**

World Headquarters/USA: 1.812.273.1622  
Canada: 1.905.812.9920  
European Headquarters/Germany: +49.771.9233.0  
United Kingdom: +44.178.747.7711  
Australasia: +60.3.7660.0285  
Latin America / Caribbean: +54.3488.431.608  
Middle East / Northern Africa: +49.771.9233.0

**© Vehicle Service Group<sup>SM</sup>**

Printed in U.S.A., All Rights Reserved. Unless otherwise indicated, ROTARY, and all other trademarks are property of Dover Corporation and its affiliates.

